







15.00h Welcome

15.10h Introduction to Deltares

15.40h Tour of Facilities

16.30h Drinks

16.45h Start ALV

17.45h Drinks/Bufferet

Delta basin – Kapuknaga  
Pacific basin – IJmuiden  
Atlantic basin – Dolwin  
Scheldt flume – Krammer  
Delta flume – Noorse  
steen/HILL block



# Enabling Delta Life – Societal Themes



**Harbours & Fairways**  
**Dikes, Levees & Dams**  
**Coastal & Offshore**  
**Water & Energy**  
**Urban**



**Flood risk**

**Operational flood management**

**Ecosystems and environmental quality**

**Nature-based engineering**

**Water and subsoil resources**

**Freshwater scarcity**

**Sustainable delta planning**

**Delta infrastructure**

**Sinking cities**

**Climate adaptation**

**The World of Deltares**  
2013-2016

# Knowledge for solutions and impact

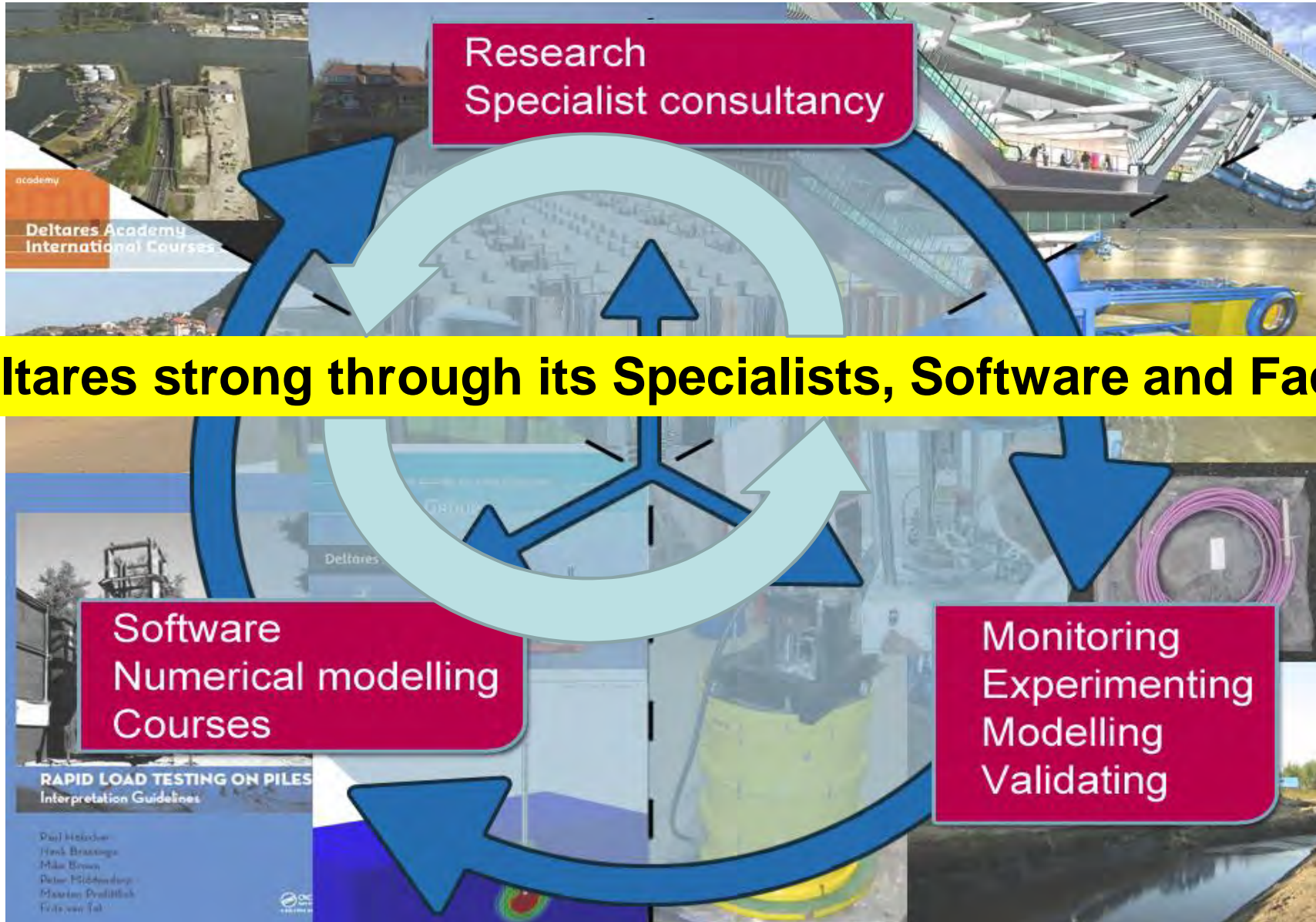

**Deltares strong through its Specialists, Software and Facilities**



# Hybrid modelling /software validation unique

Procesmodel +  
schematisations

detail infra  
interaction

Prototype  
behaviour

Numerical model

Physical model

Prototype

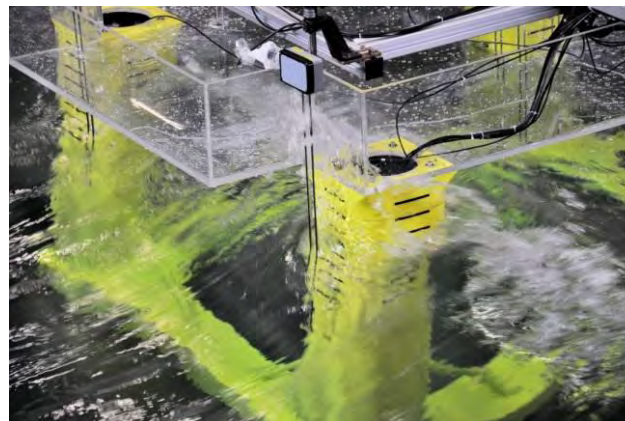
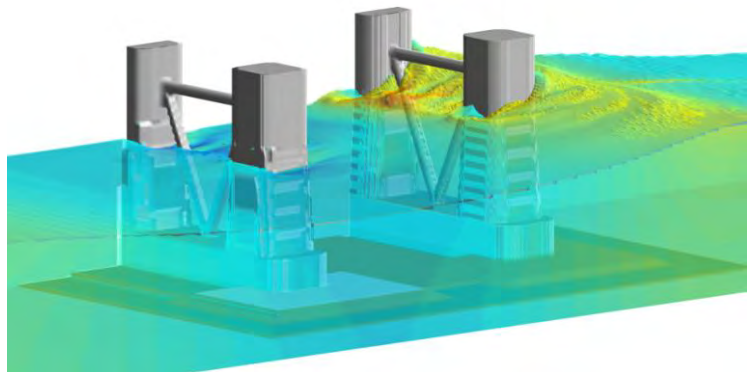



# Grand opening Delta Flume – tsunami for TopSector



300mx5mx10m  
Hs = 2.2 m  
Hmax = 4.5 m  
Full ARC  
Tidal Motion



**Deltares** opening



**Deltares**



# Gross turnover per societal theme

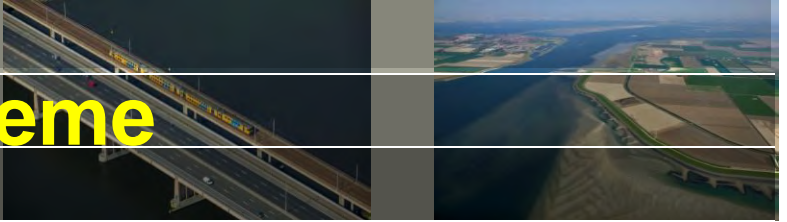

2013 - 2014

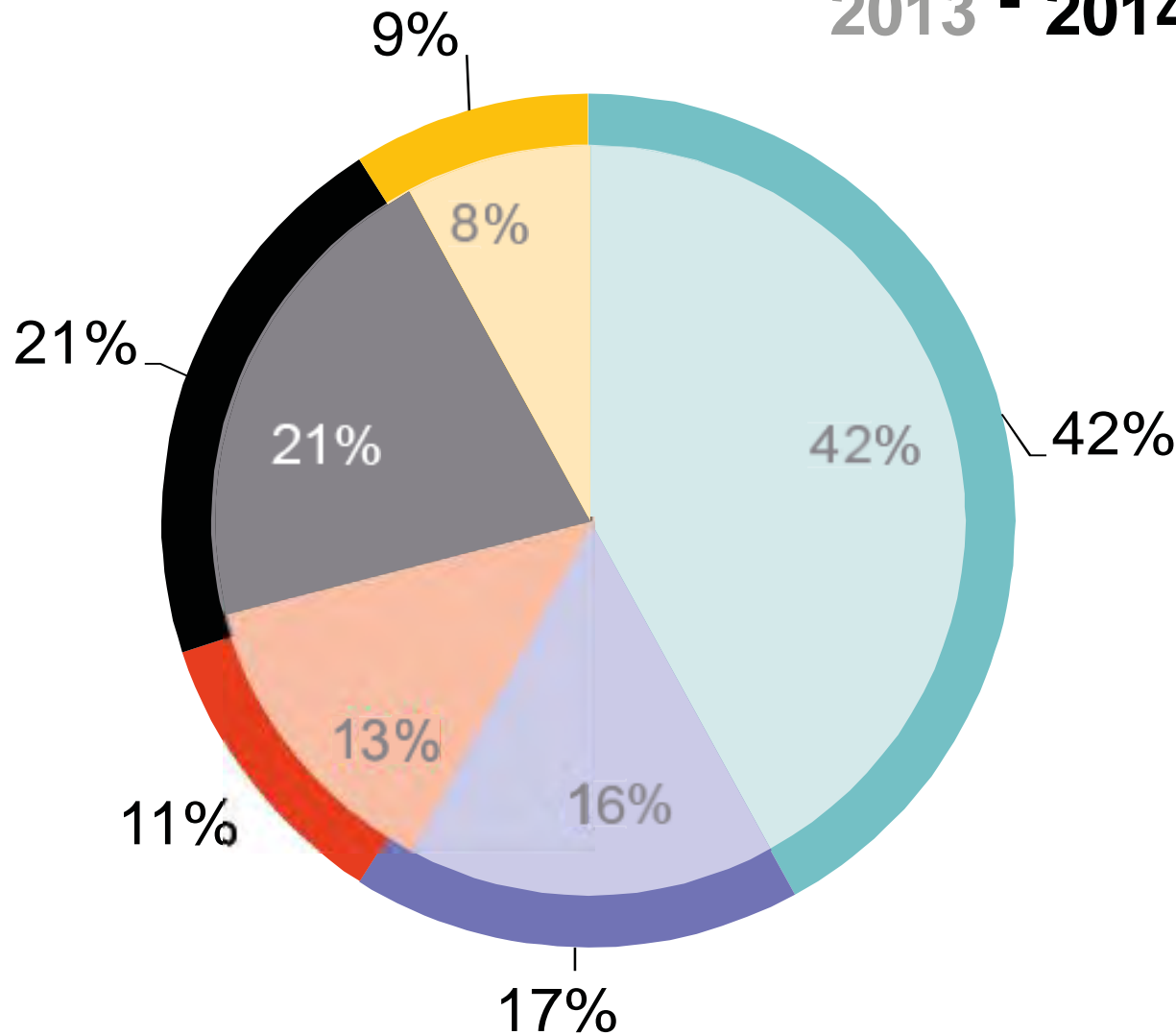

**35% Hydraulic/Geo Engineering**

- Flood risk
- Ecosystems and environmental quality
- Water and Subsoil Resources
- Delta Infrastructure
- Sustainable delta planning

**Total 105 Meuro gross turnover**



# Gross turnover per region

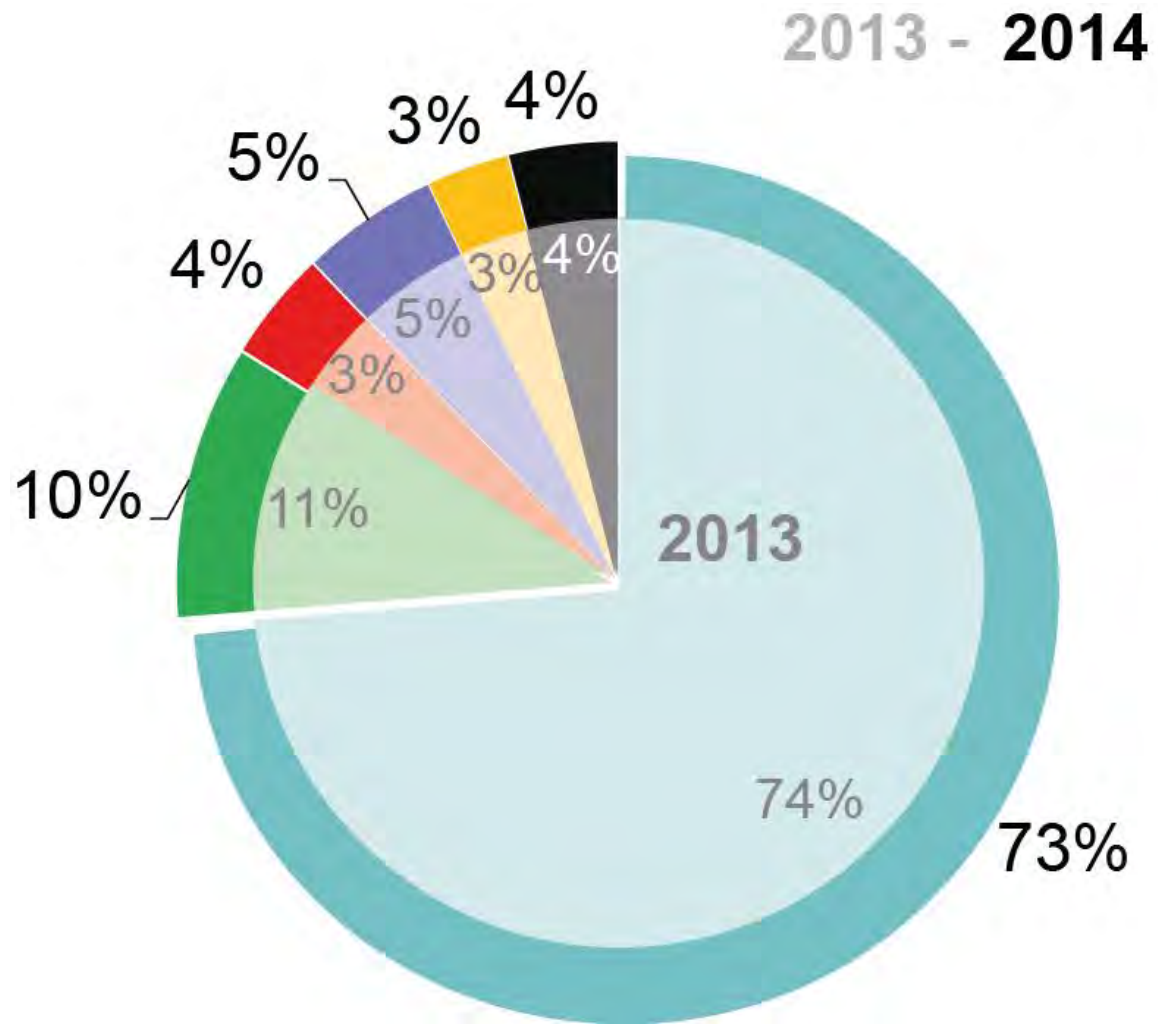
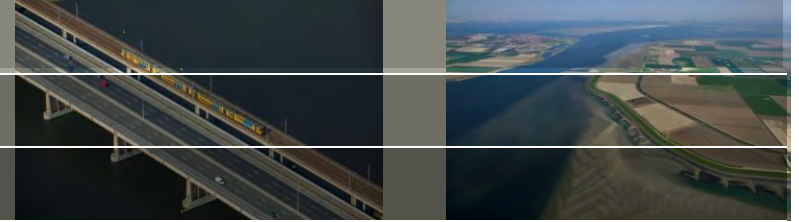

**70% Netherlands  
30% Overseas  
(40% ambition)**

- The Netherlands
- The rest of Europe
- North America
- Asia
- Middle East
- Others

**Total 105 Meuro  
gross turnover**

New offices 2014:

Deltares Brazil Idta  
Branche Deltares Dubai



# Gross turnover per type of client

2013 - 2014

**35-40% contract research**  
**30-35% public**  
**30% private**

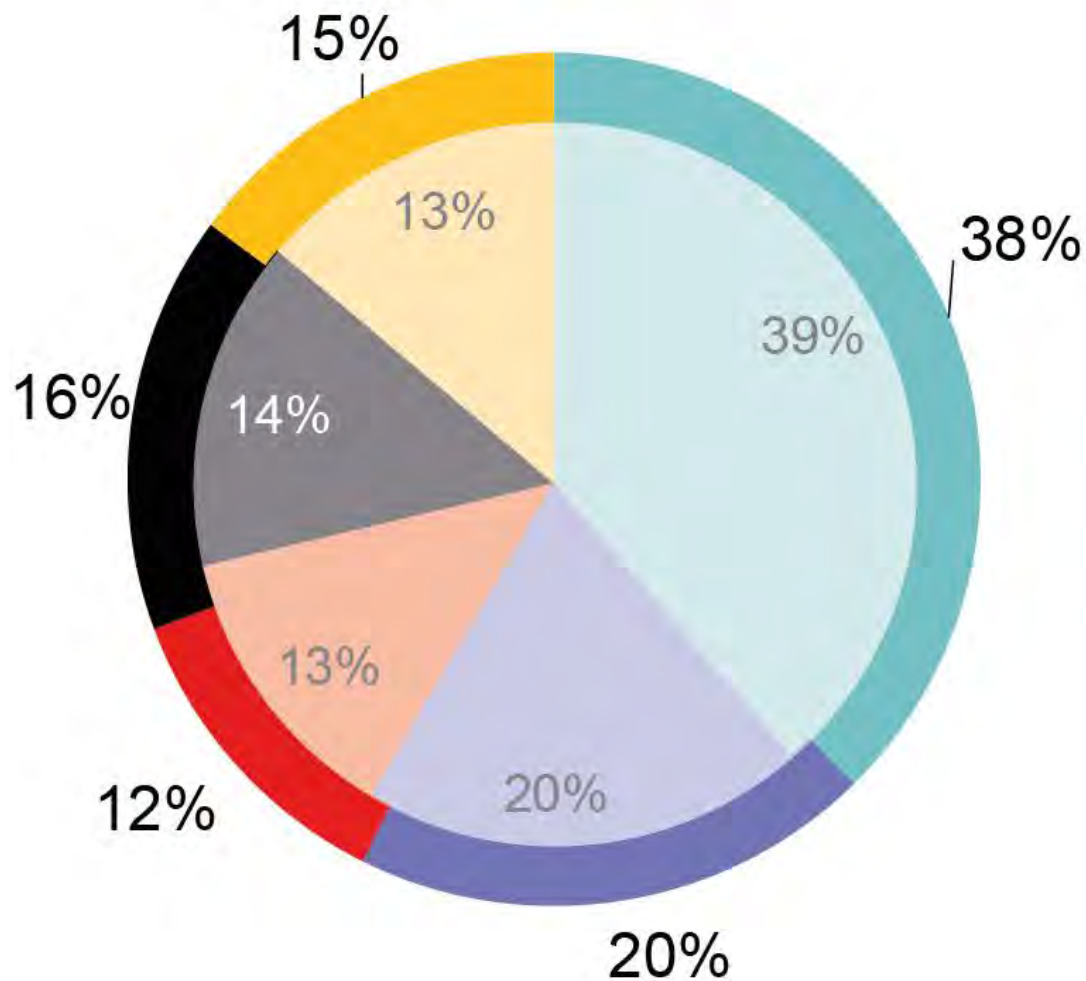

- Demand driven research
- Dutch government
- Governments other countries
- Dutch corporate sector
- Corporate sector other countries

**Total 105 Meuro gross turnover**



# Some 825 Employees

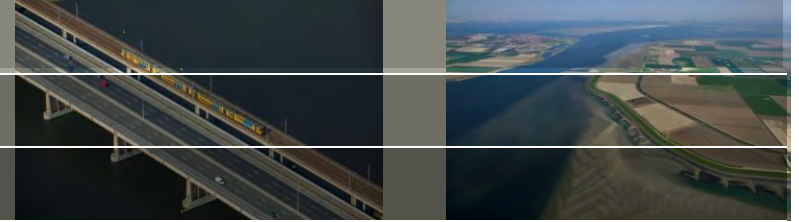

**32**  
nationalities

## NATIONALITIES (IN NUMBERS OF EMPLOYEES)

In total there are 32 nationalities working at Deltares (beside the Dutch).

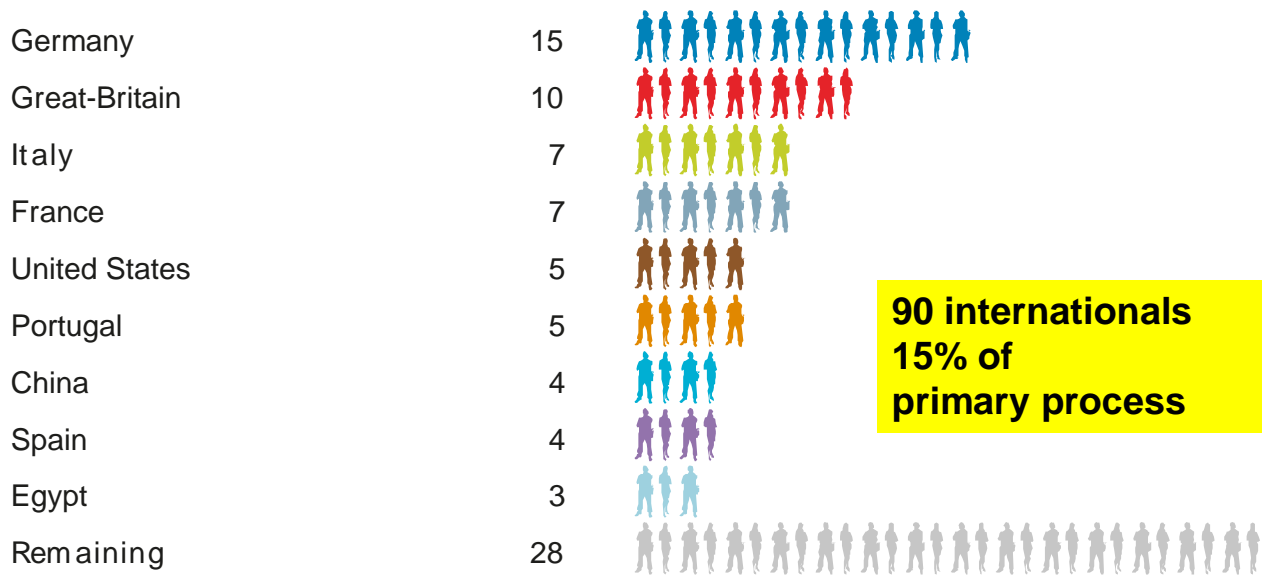

**90 internationals**  
**15% of**  
**primary process**

## Some 75% Academics

### EDUCATION

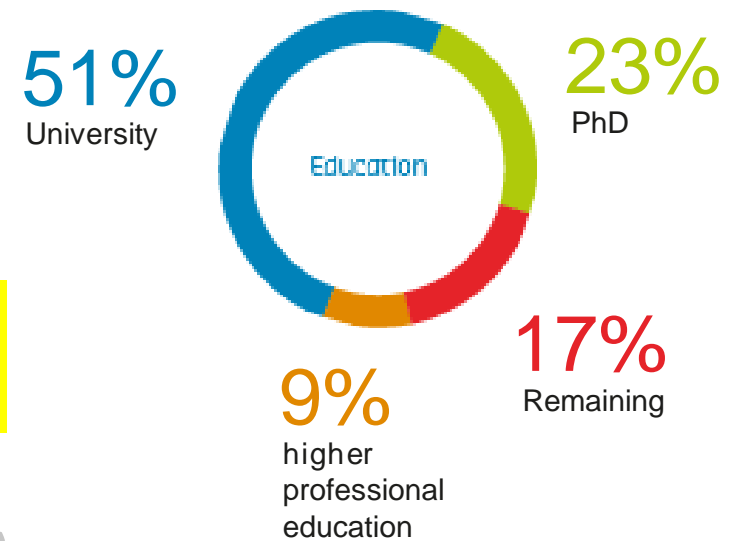



# Co-creation and financing: public/private



**TOPSECTOR ENERGIE**  
Empowering the new economy



**TOPSECTOR  
WATER**



Enabling new technology



**Nationaal Kennis- en Innovatieprogramma Water en Klimaat**



# Co-creation and financing: private (JIPs)



**JIP CODES**  
Coastal tool



**JIP OSCAR**  
scour

**JIP Open Foam**  
Wave-Structure interaction

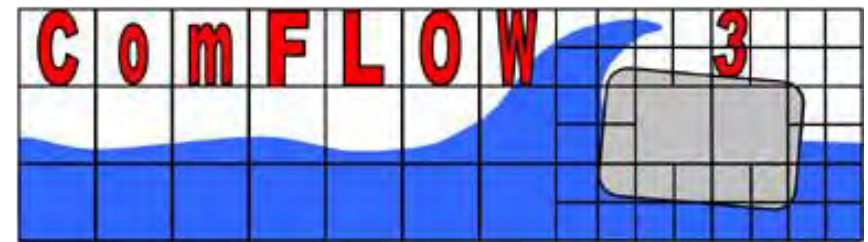

**JIP FIST**  
freespans

**JIP Open Filters**





# SME – Deltares link 10% ‘waterbouw’ turnover)

- SME website
- Free access to facilities
- EZ-vouchers
- Climate-KIC vouchers
- EU-calls
- JIP-calls
- Topsector calls (but Deltatechnology difficult?)
- IJkdijk – sensor technology
- Geo- and Hydro-software & Rapid Assessment Tools
- ONL- SME events
- Klankbord-meetings Delta Infrastructure



# SME – Deltares link (flood barrier)

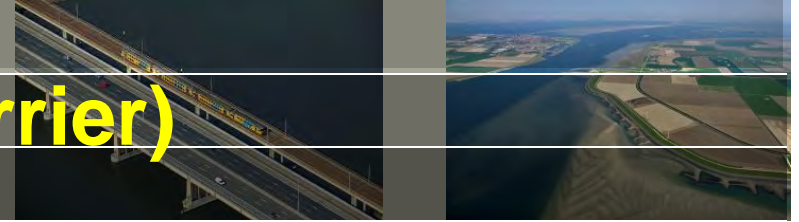

EXTRA flood barrier



DUTCHDAM

DYNEEMA tsunami barrier

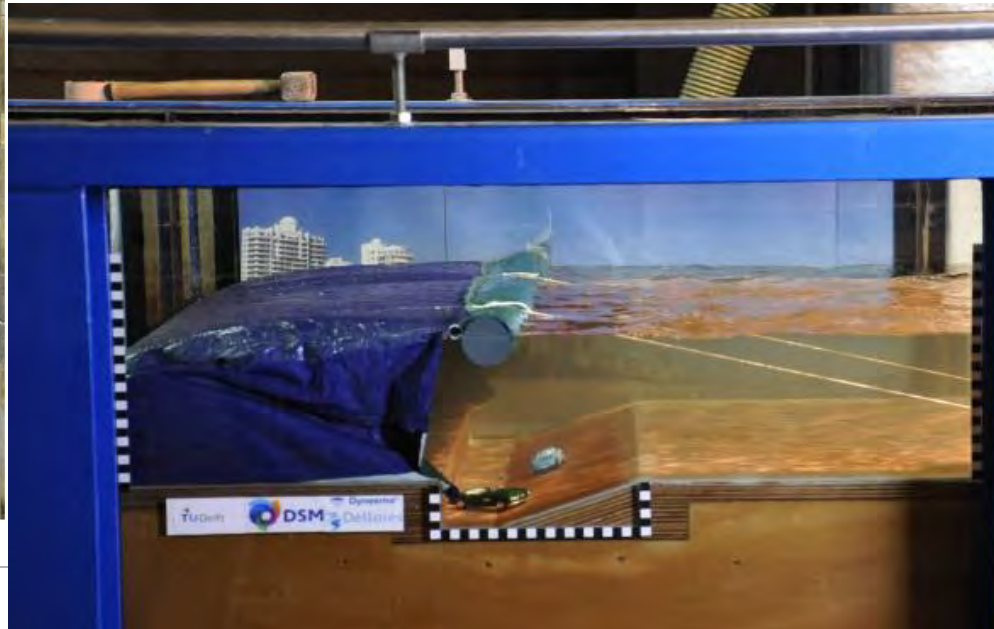

GEOTEXTILE TUBE



Deltares



# SME – Deltares link (protection)

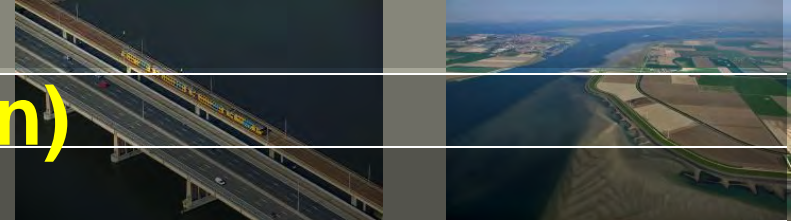

**HILL BLOCK  
revetment**



**TOUR**

**LBN-Verkalit  
permeability  
testing**

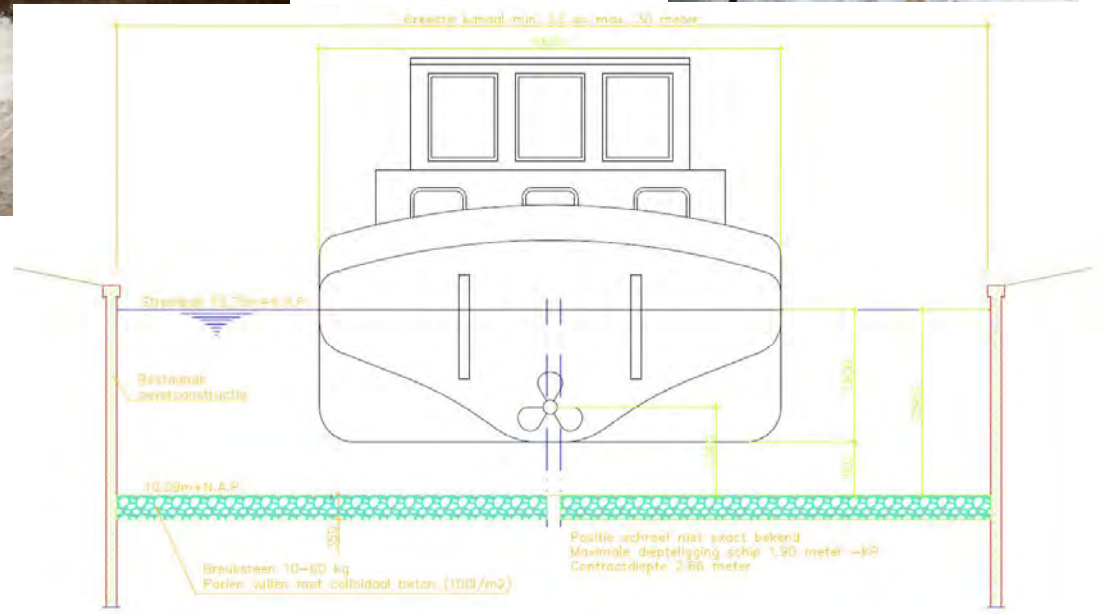

**THEOCRETE  
friction tests**

**BETOMAT bottom protection**

**HILL  
ALTENA-Ronaton  
HOLCIM  
LBN/BERDING  
HARINGMAN-Hydroblock**

date

15



# SME – Deltares link (energising deltas)

CFD model Roompot 08 met 5 turbines T200

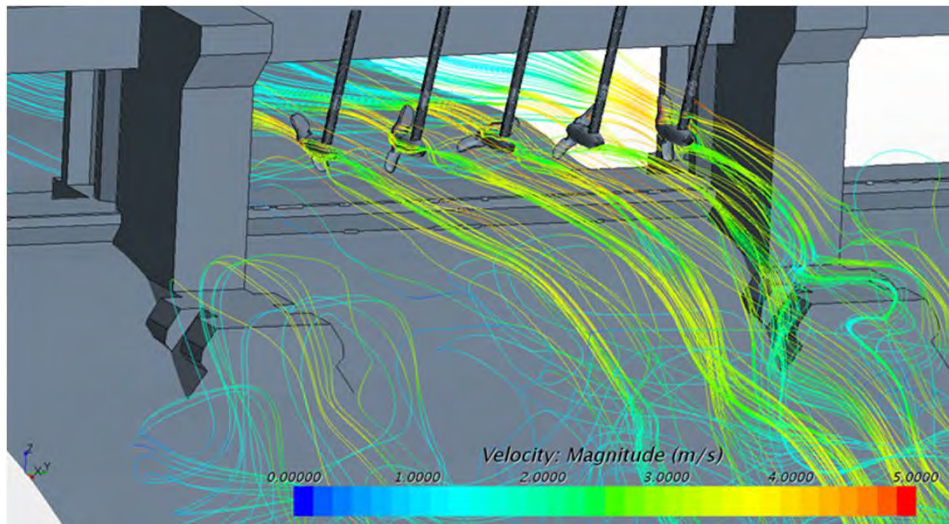

Tocado turbines succesvol geïnstalleerd september 2015

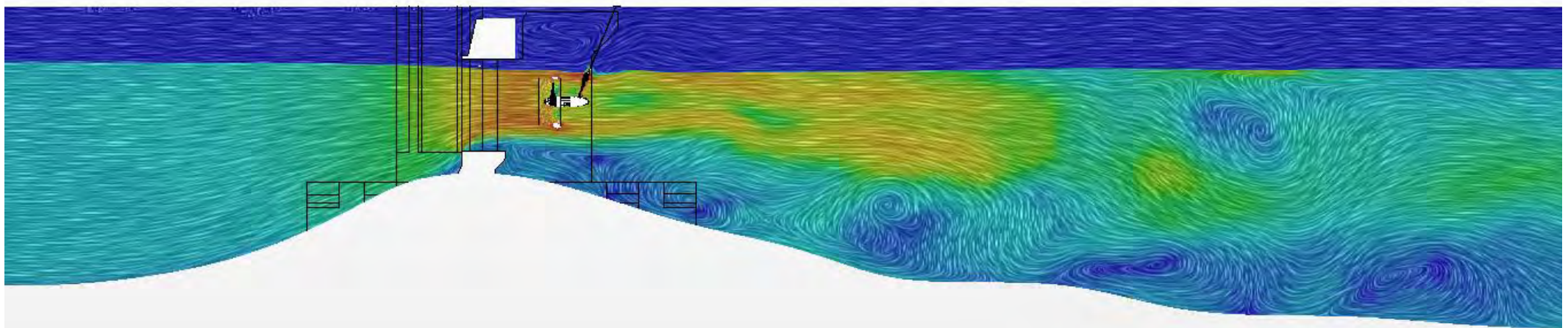



# SME – Deltares link (blue energy)

Blue Energy Pilot plant at Breezanddijk, Afsluitdijk (omgevingseffecten)

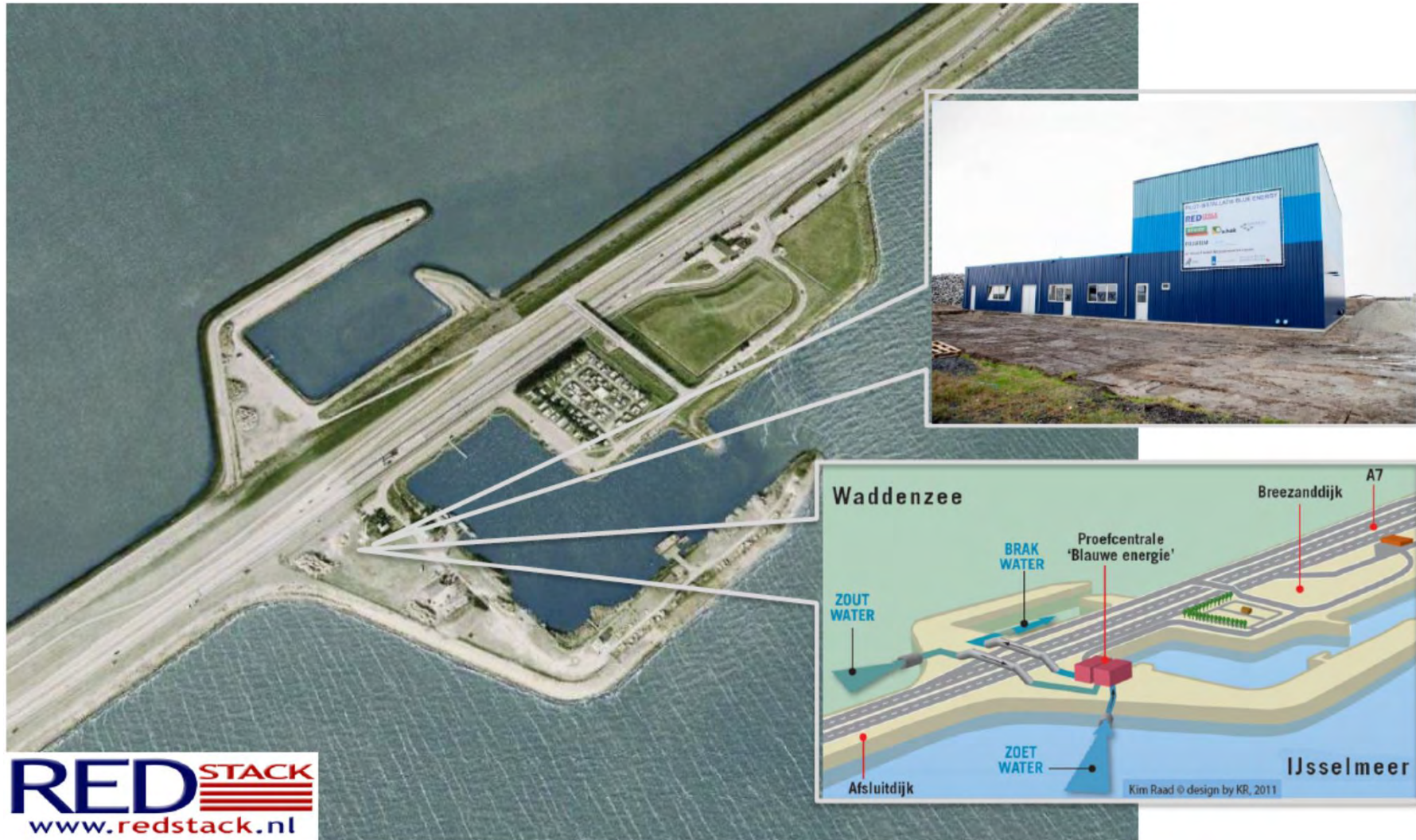



# SME – Deltares link (ocean cleanup)

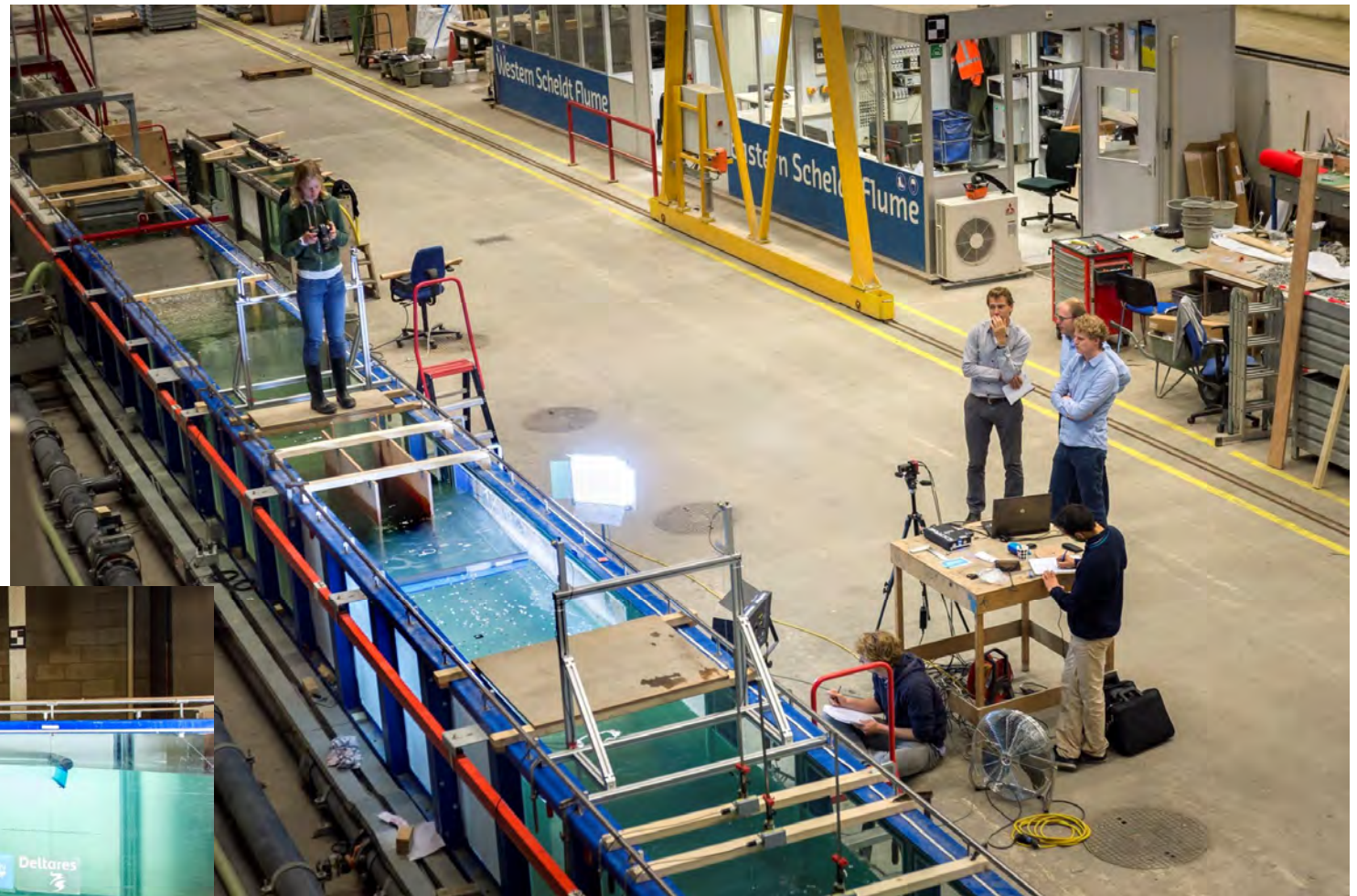



# Examples of national knowledge alliance

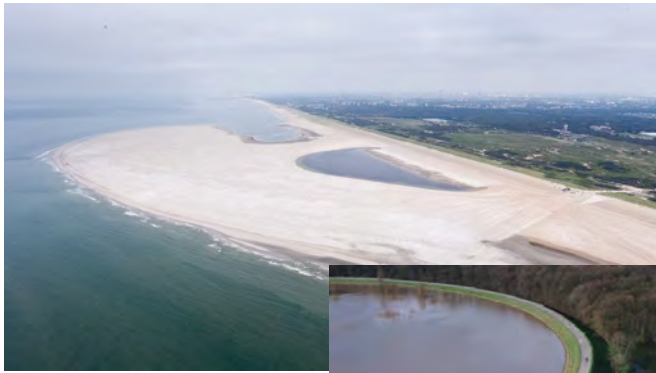



# I&M alliance - Coastal policy innovation



Rijkswaterstaat  
Ministerie van Infrastructuur en Milieu

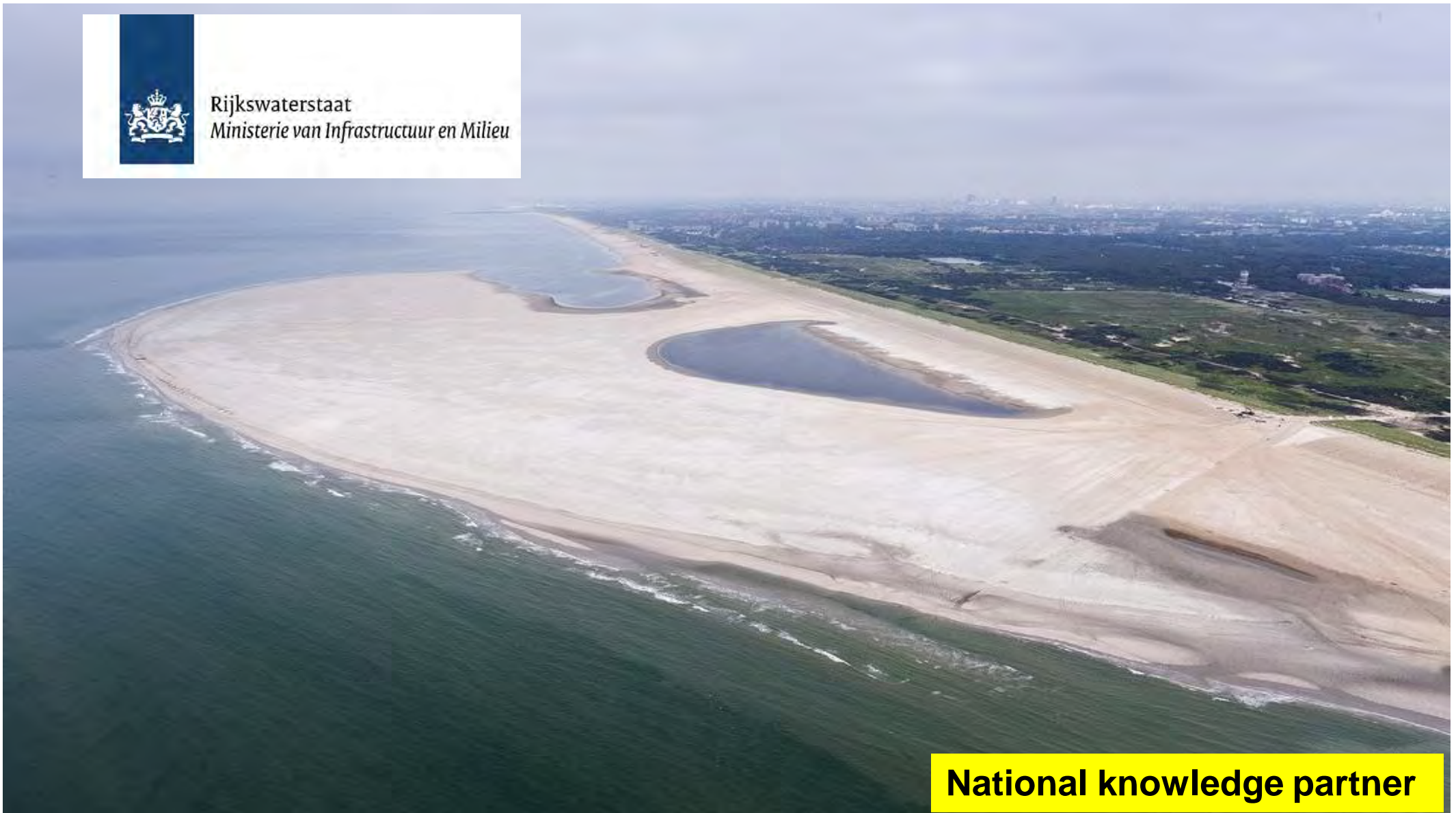

National knowledge partner

- Sand engine: 128 hectares (256 soccer fields)
- Protection against rising sea levels and space for nature

**Deltares**



# I&M alliance - Flood safety regulation (WTI)



Rijkswaterstaat  
Ministerie van Infrastructuur en Milieu



National knowledge partner

- Innovative solutions for crisis management during floods
- Making the total system smarter: the dike, the people *and* the locality (instrumentation, flood control room, evacuation plans)

**Flood Control**  
2015



# I&M alliance – RvR policy implementation

 Rijkswaterstaat  
Ministerie van Infrastructuur en Milieu



Volker InfraDesign

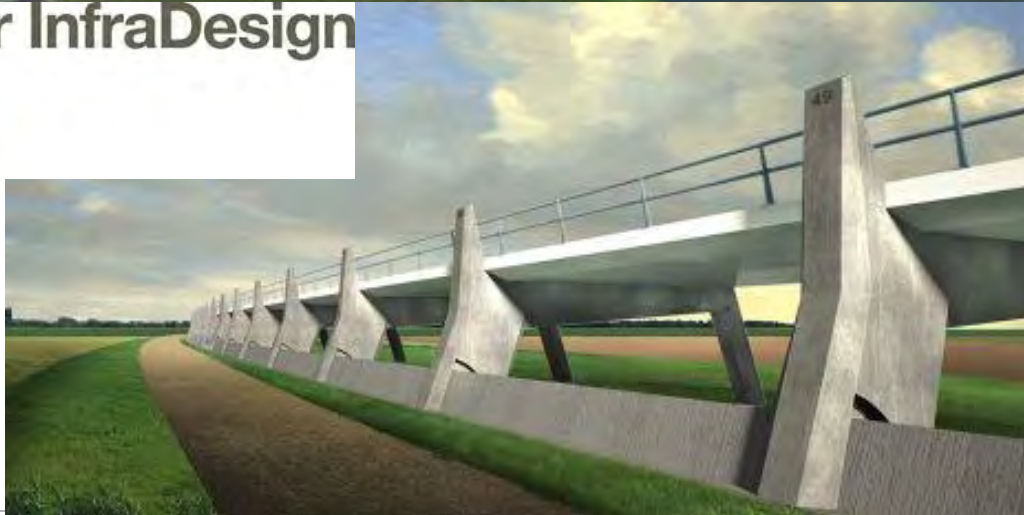

National knowledge partner

**Deltares**



# I&M alliance - Salt/fresh water balance VZM

## Krammer locks

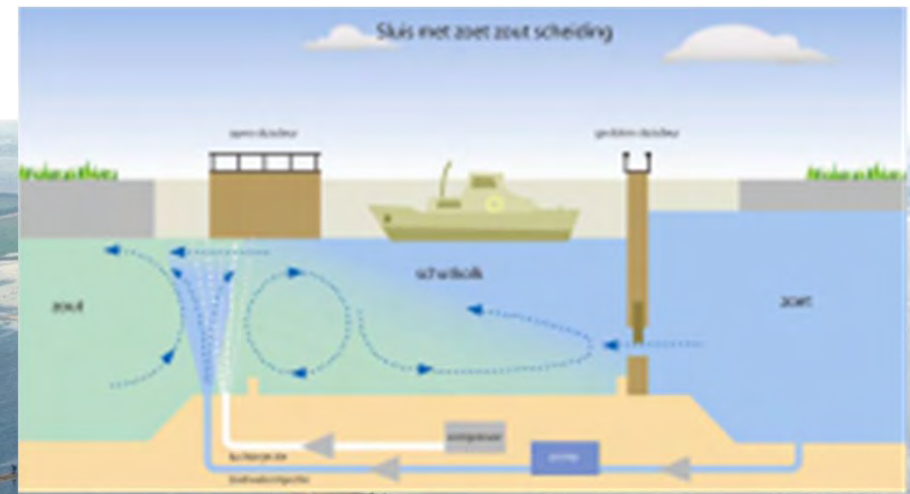

Air- and water screens together with freshwater flushing limit salt wedge penetration due to locking process



TOUR



# I&M/EZ alliance – independent advisor

N/Z-lijn Amsterdam – Hedwige polder – Gaswinning Groningen

National knowledge partner

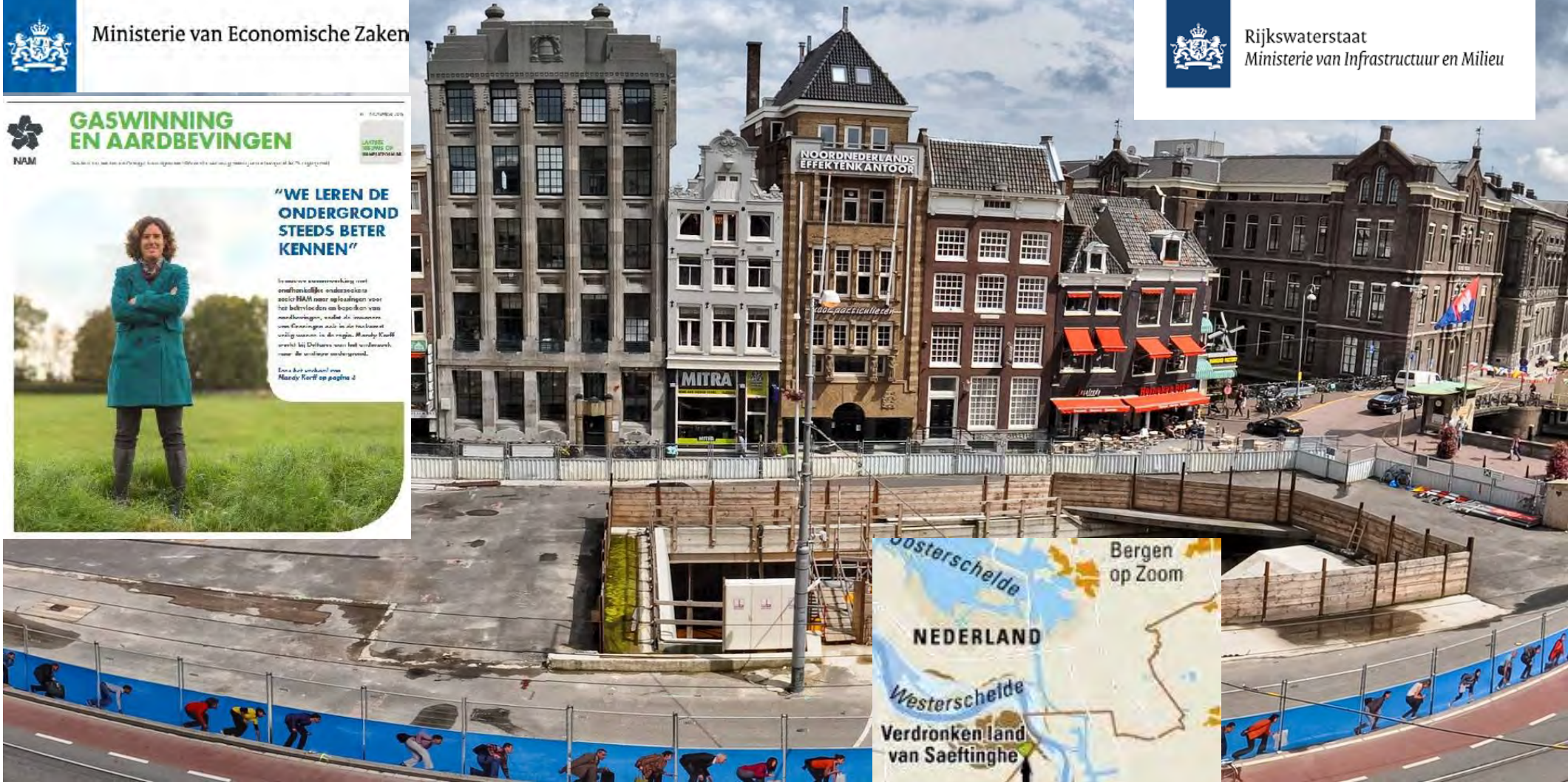

- Strategic advisor and second opinions
- Support for risk-driven approach

**Deltares**



# HbR alliance - Entry/exit Rotterdam harbour navigability requirement during construction MV2

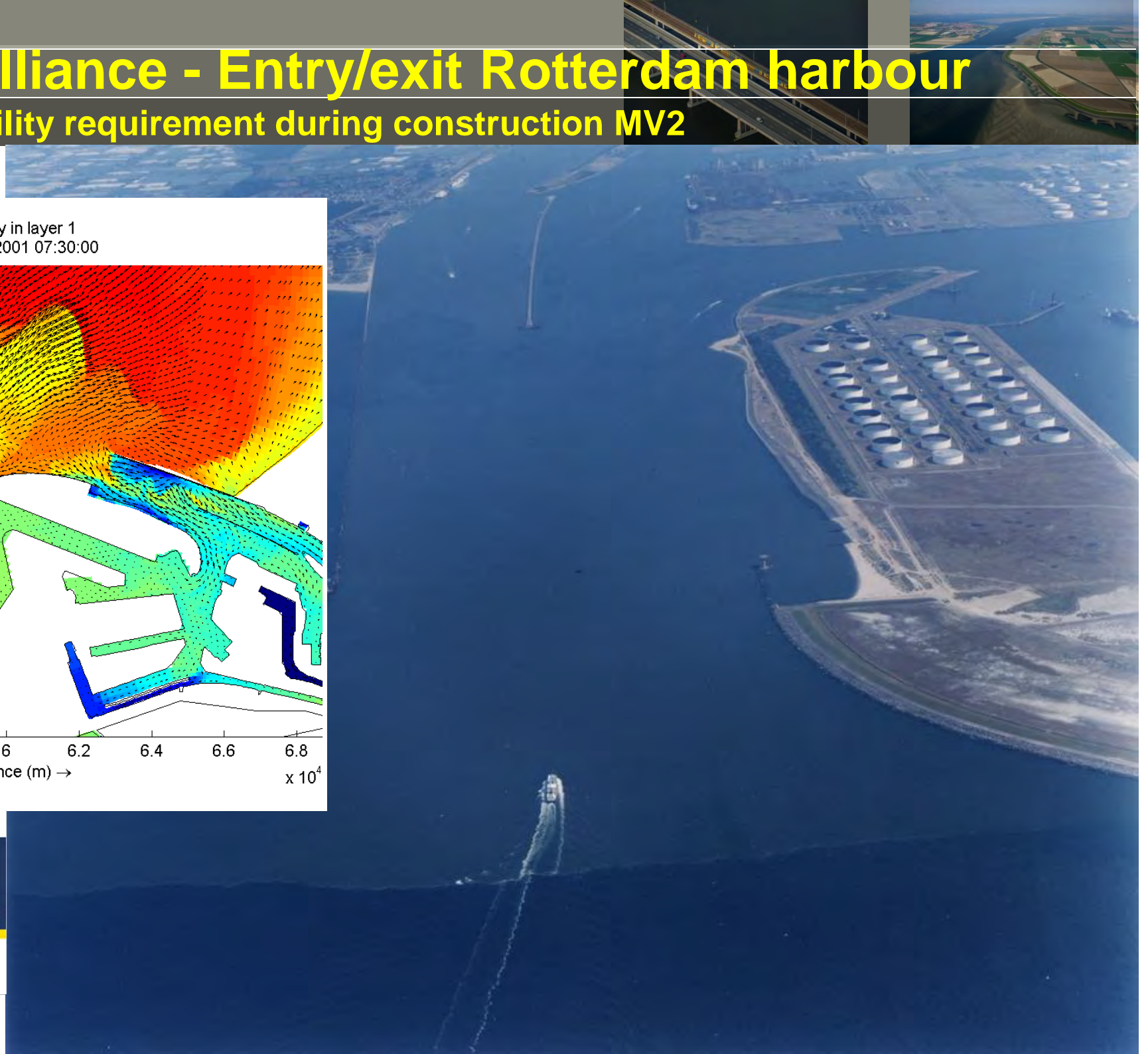
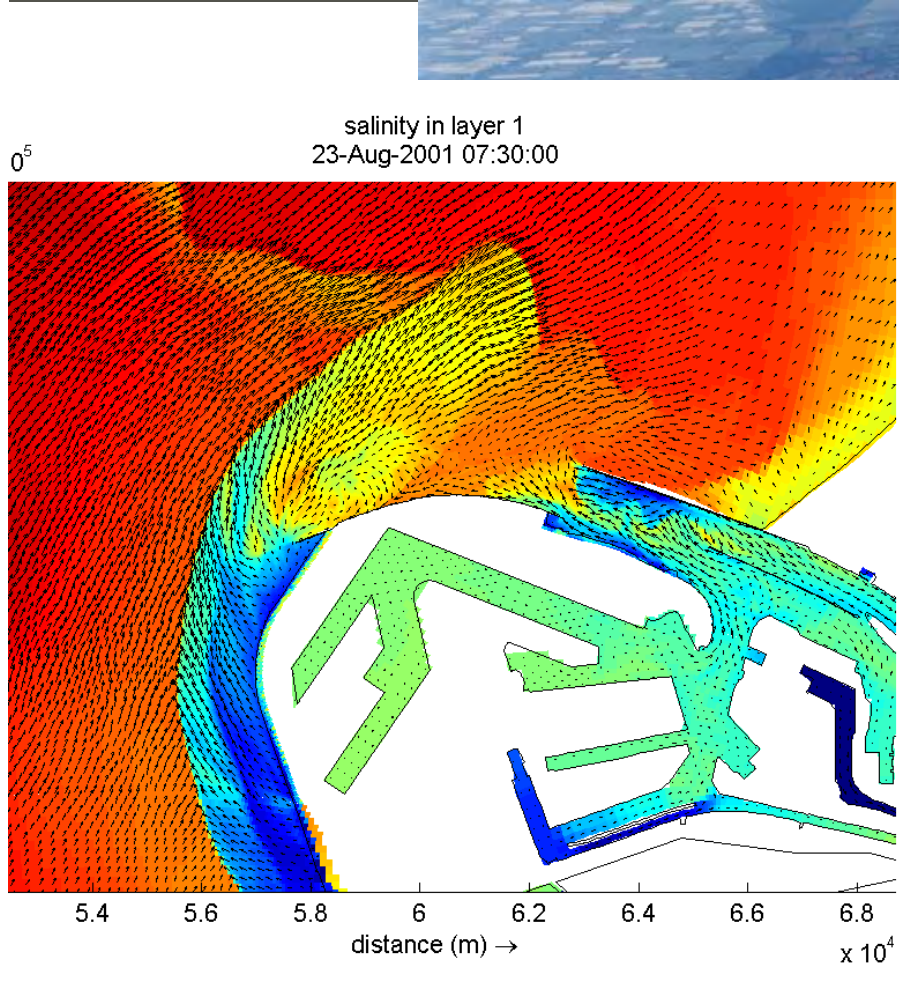



# HbR/PUMA alliance – MV2 design innovation



## National knowledge partner

- Research and advice on port design
- Testing coastal defences using scale models
- Tidal flow predictions for ships during the construction phase
- Environmental impact assessments and cooling water discharges



**Deltares**



# HbR alliance - Guidelines thruster loads at quay



In addition to the end-report of PIANC WG48, the propeller-induced hydraulic load, resulting scour and required scour protection are addressed in order to validate and extend existing guidelines.

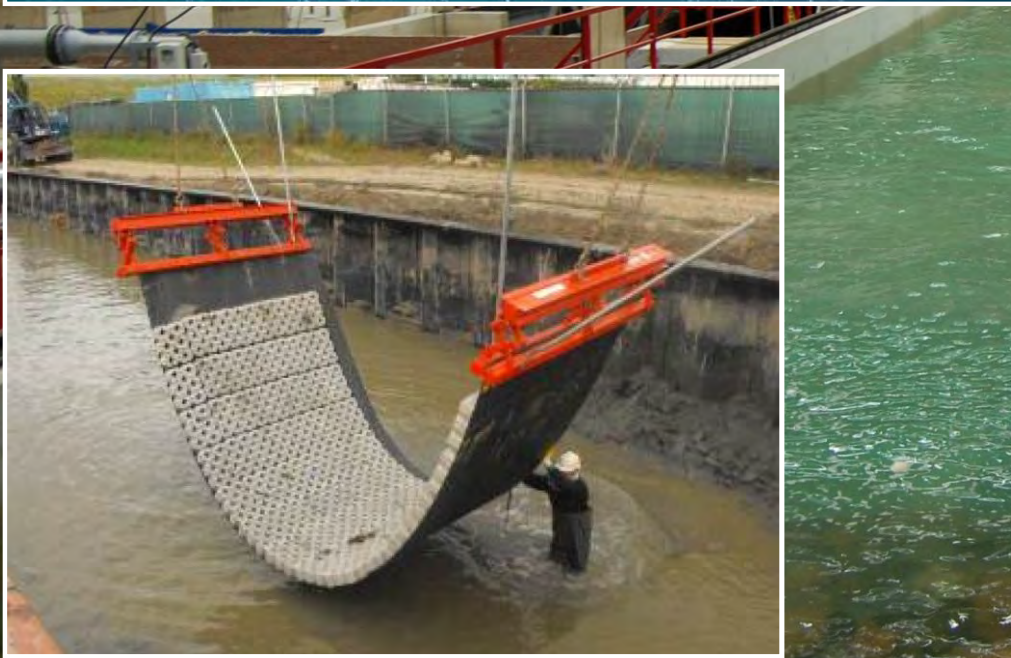
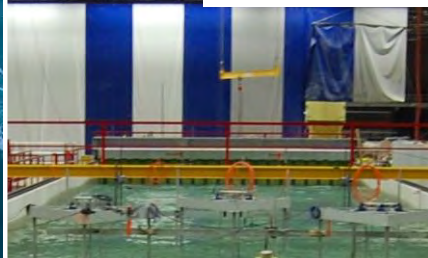



# I&M/HbA alliance – A'dam lock (world-biggest!)



National knowledge partner



545 m x 70 m x 17,5 m



Northern lock

Southern lock

Middle lock

Port of Amsterdam



# Scaled density model 1:40

to support numerical modelling

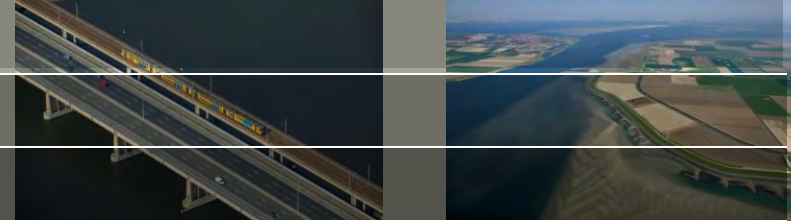

TOUR

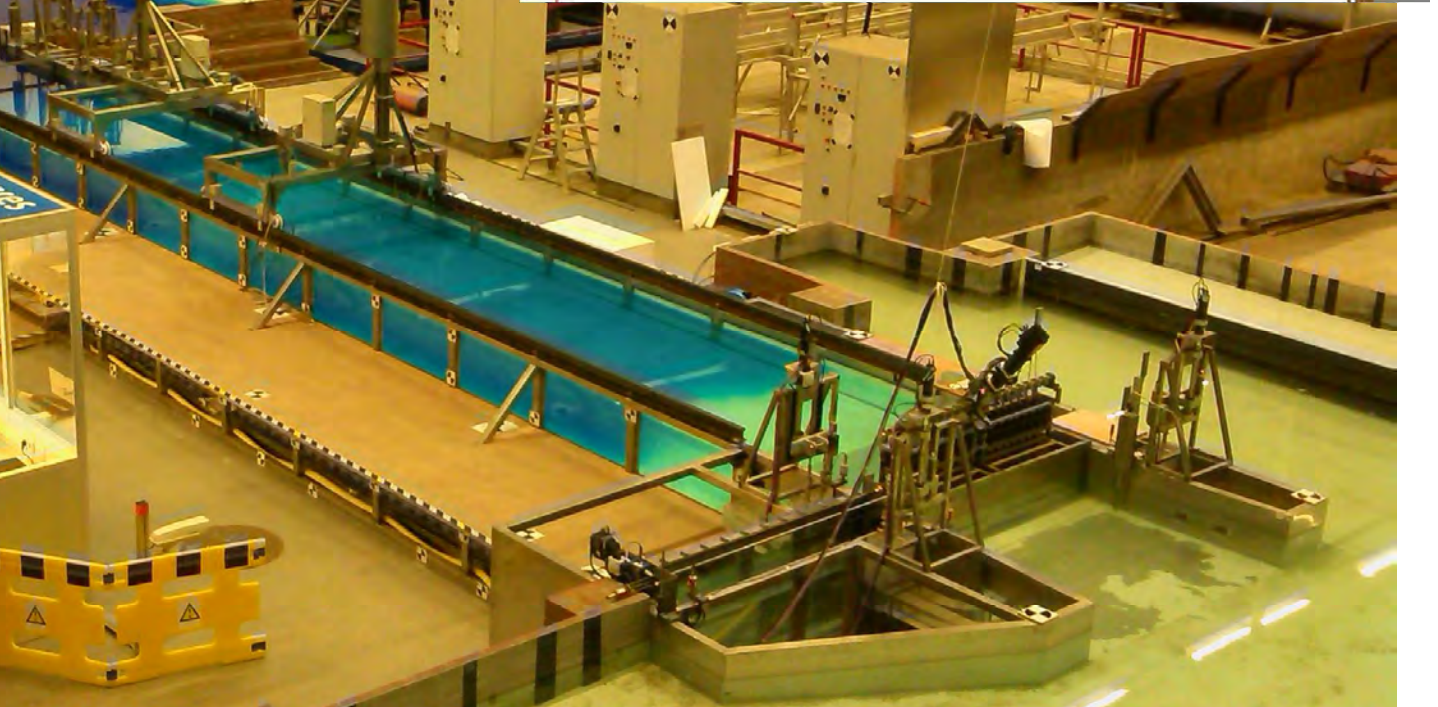
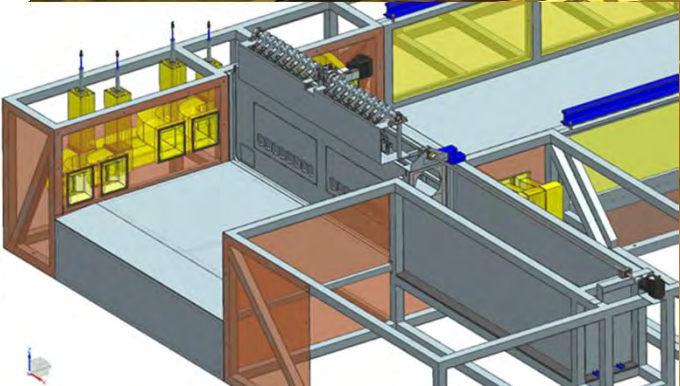
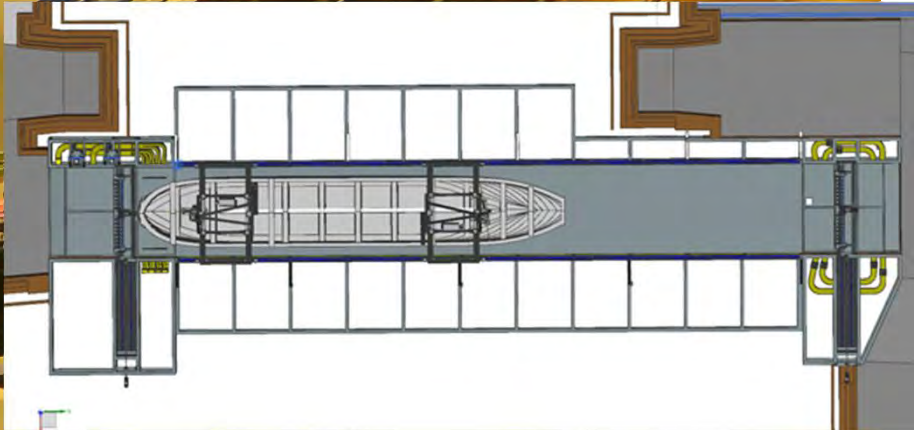
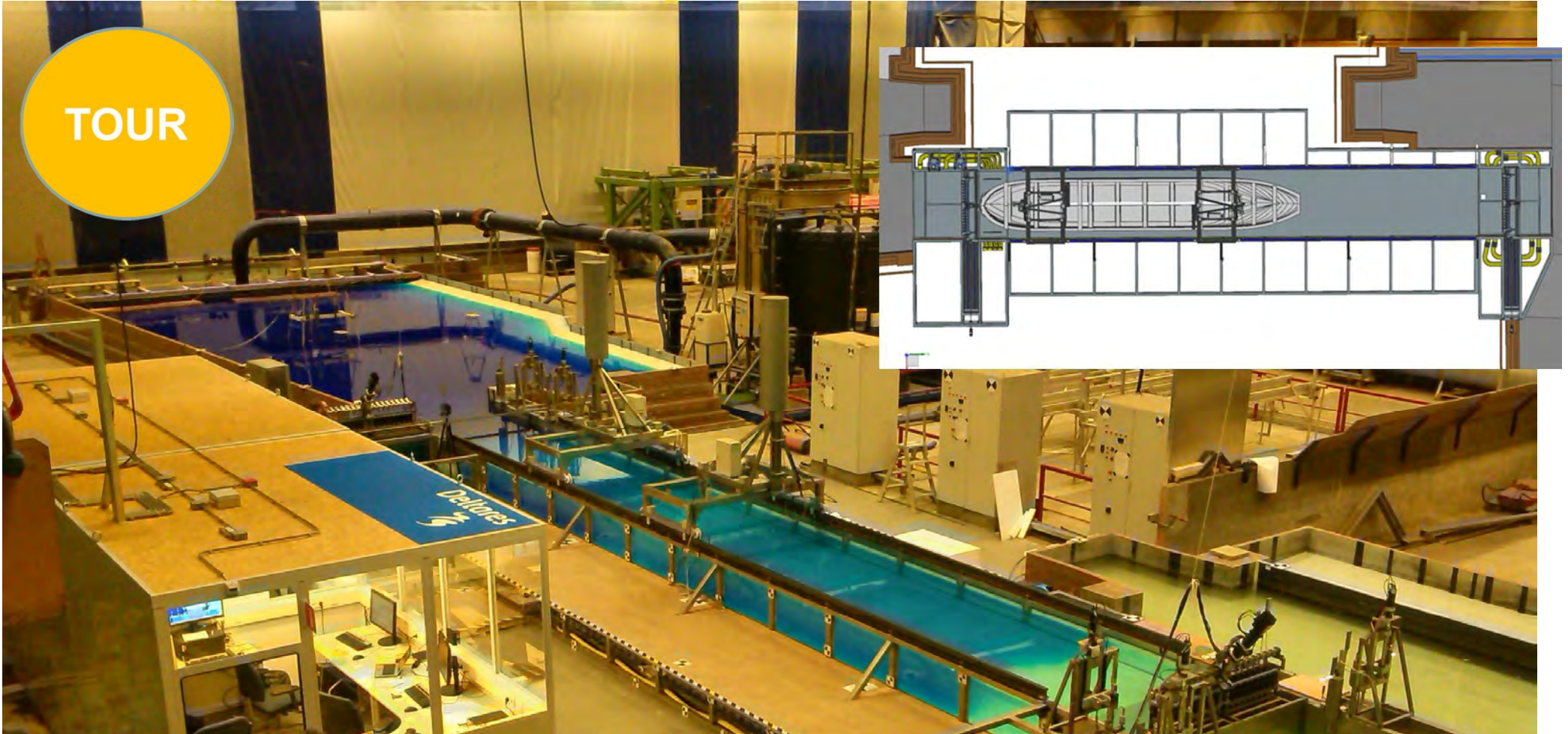

Port of Amsterdam



# From national alliance to world alliance

**Strategic knowledge alliances to accelerate knowledge growth and innovation:**

**Singapore-Delft Water Alliance  
NCICD Integrated Coastal Developm.  
NOAA-USGS-USACE-ONR  
KISR-Adwea-Masdar-KAUST-QatarF.**

**Scientific network  
Strategic alliances  
Open source software  
Community development  
Academy**

**WE DARE TO SHARE  
Independent, reliable, innovative**





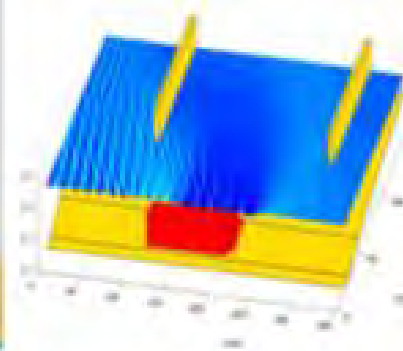
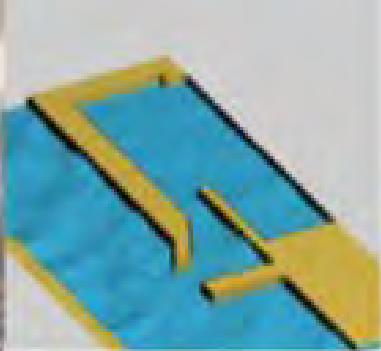

clm3d0000.dat (time

## Our software:

- Software is one of the most important **knowledge bases** of Deltares.
- Knowledge transfer through **distribution of our software** is one of Deltares' key activities.
- Our software **applications** cover our expertise including e.g. coastal waters and estuaries (Delft3D), rivers and urban water management (SOBEK), coastal design tools (CHES, Comflow and M-Series), operational forecasting systems (FEWS) and industrial hydrodynamics (WANDA).

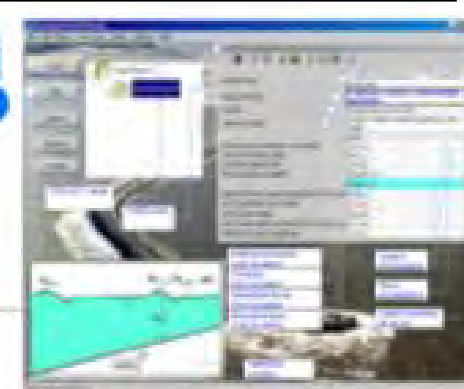
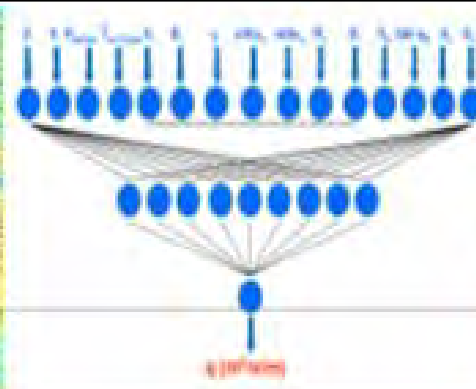
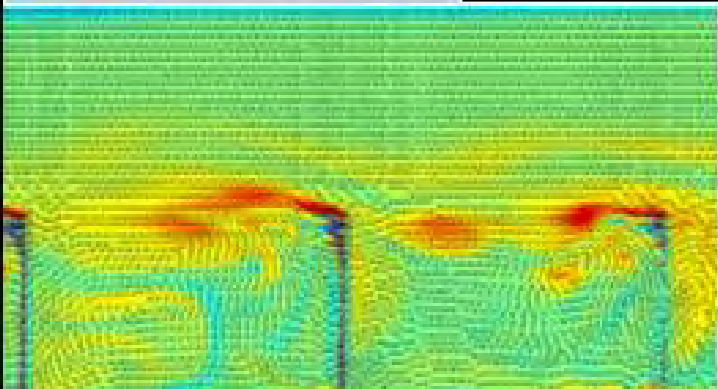
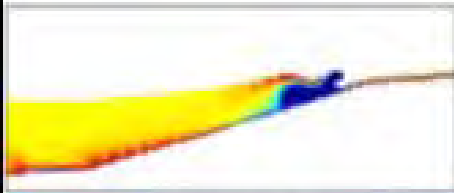
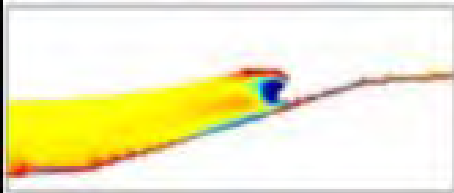
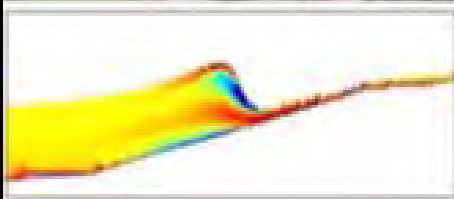
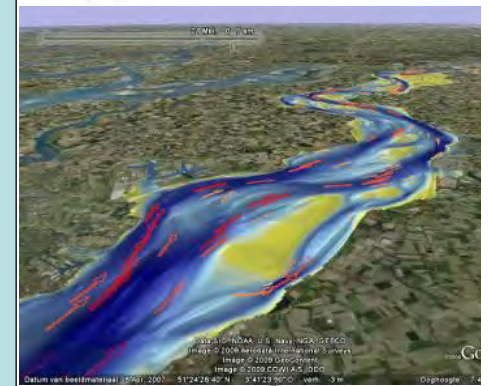
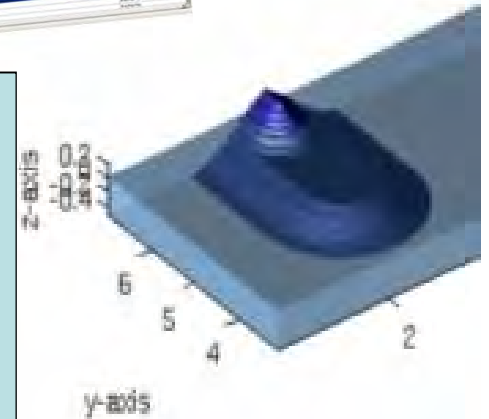



# Sharing software – open source

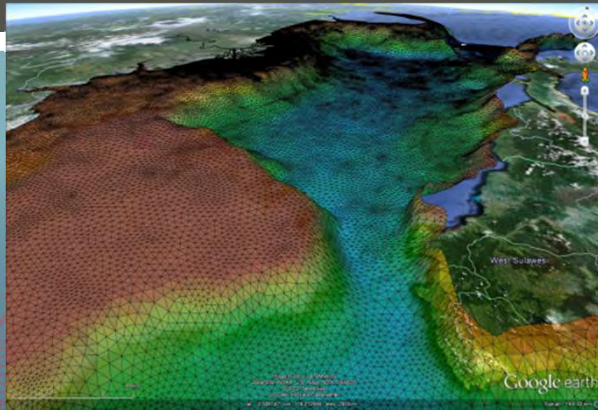

IAHR Industry Innovation Award 2015

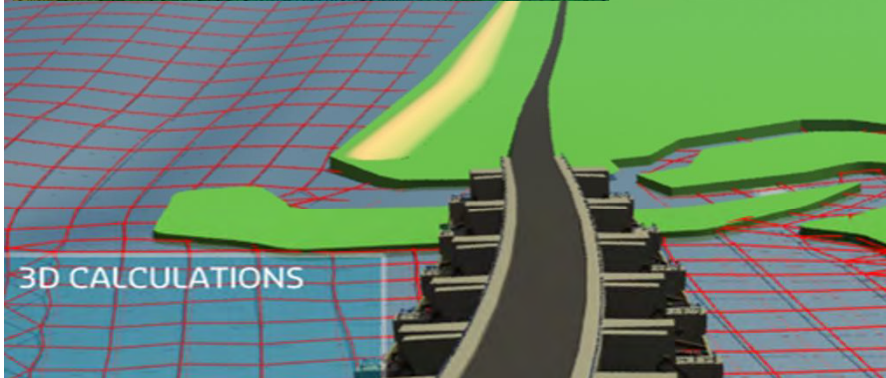

**TU Delft** **UNESCO-IHE** **Deltares**  
Institute for Water Education *Enabling Delta Life*

**500 attendees from some 50 nations**

**Delft Software Days 2015**  
Delft, The Netherlands

- Deltares software used in more than 100 countries
- Open software establishes sharing community
- Over 1100 registrations on open source portal



# Sharing facilities (Deltares EU-lead in Europe)

## In-situ and experimental lab facilities

In-situ measurements



laboratories



Full-scale test facilities



Large-scale experimental facilities

Small-scale experimental facilities



Deltares



# Sharing knowledge (incl. iD-lab)

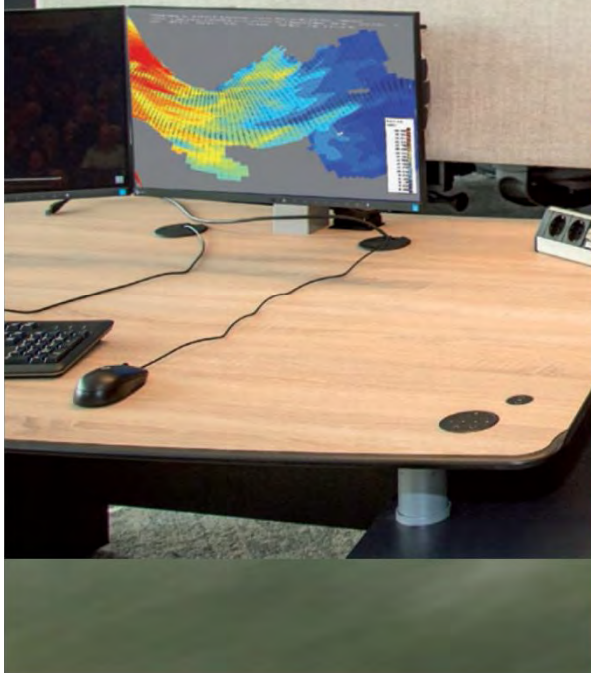

**Serious game: Port of the future**

Deltares Academy ([www.deltares.nl/en/academy](http://www.deltares.nl/en/academy))



Through serious gaming, (open source) software, publications, data and models, doctorate supervision, Deltares Academy, workshops, congresses and projects/research projects, Deltares Software Days



# Sharing knowledge: conferences (paper awards)



Lockfill software

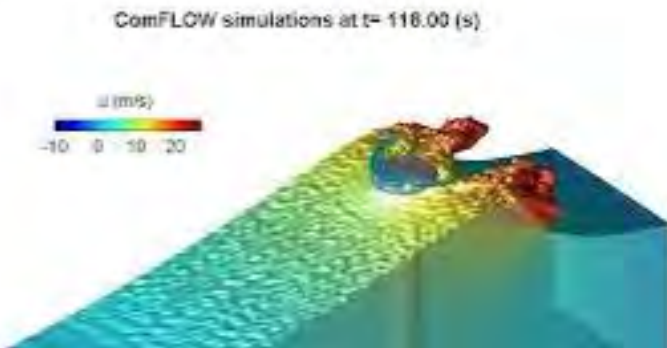

Paper 105 -Comparison of Scale Model Measurements and 3D CFD Simulations of Loss Coefficients and Flow Patterns for Lock Levelling Systems

VAN DER VEN, P.P.D., VAN VELZEN, G., O'MAHONEY, T.S.D., DE LOOR, A.

Deltares, Hydraulic Engineering, Delft, The Netherlands

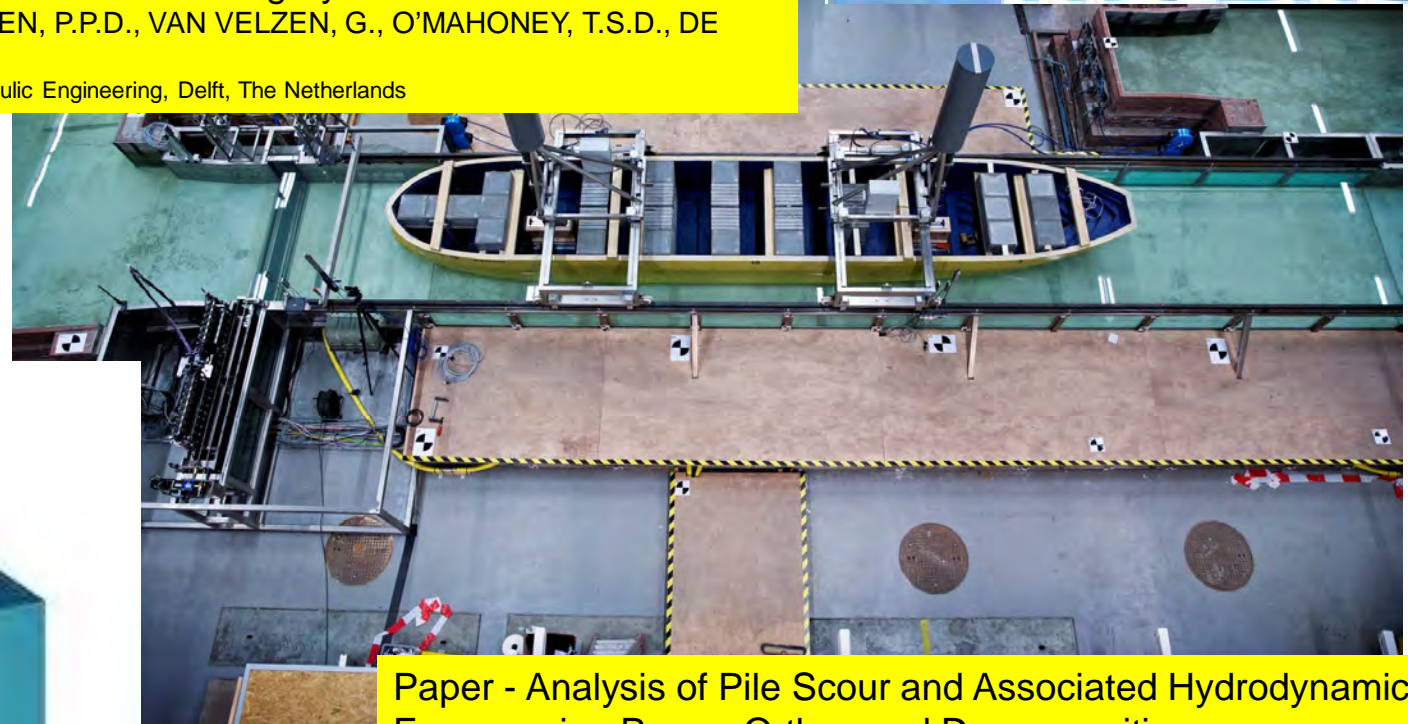

Paper - Analysis of Pile Scour and Associated Hydrodynamic Forces using Proper Orthogonal Decomposition,

JAKOBSEN, N., VAN VELZEN G,

Deltares, Hydraulic Engineering, Delft, the Netherlands



**icse2014**

7th International Conference on Scour and Erosion  
2nd - 4th December 2014 • Perth, Western Australia

**Deltares**







# Examples of international knowledge alliance



Deltares



# Nakheel alliance - Palm Islands Dubai

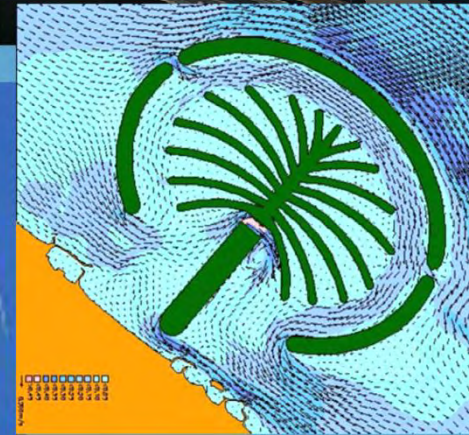
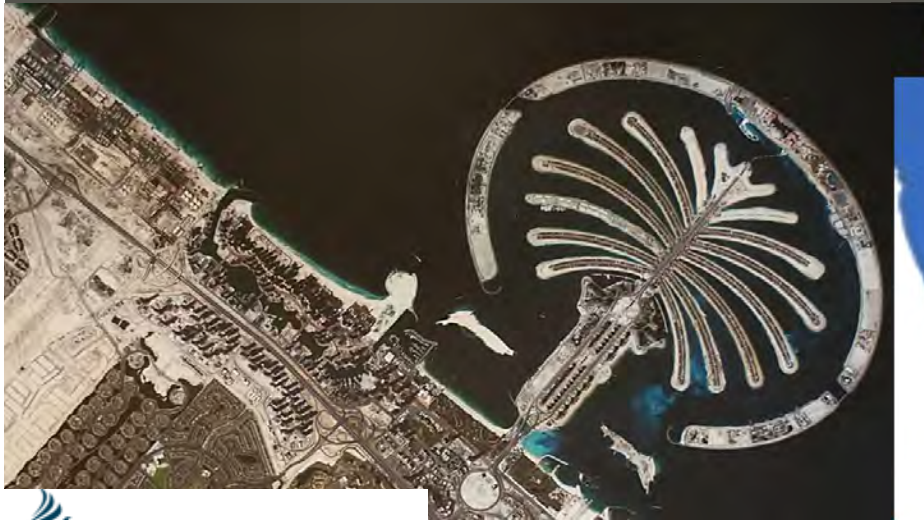

**International knowledge partner**

- Advice about coastal defence and erosion, water circulation, water quality, site preparation, compression and earthquake precautions





# SDWA Alliance - Marina Bay



Water for All: Conserve, Value, Enjoy



HOUSING &  
DEVELOPMENT  
BOARD



**International knowledge partner**

**NUS Deltares**  
BRIDGING SCIENCE & SOCIETY



singapore-delft water alliance

- Marina Bay: from estuary to freshwater reservoir
- Objective: an operational water quality management system
- Collaboration with the Singapore Public Utilities Board

**Deltares**



# NCICD alliance - Great Garuda Development

Pluit City, Kapuknaga + Pusair twinning + NCICD programme management

Witteveen + Bos

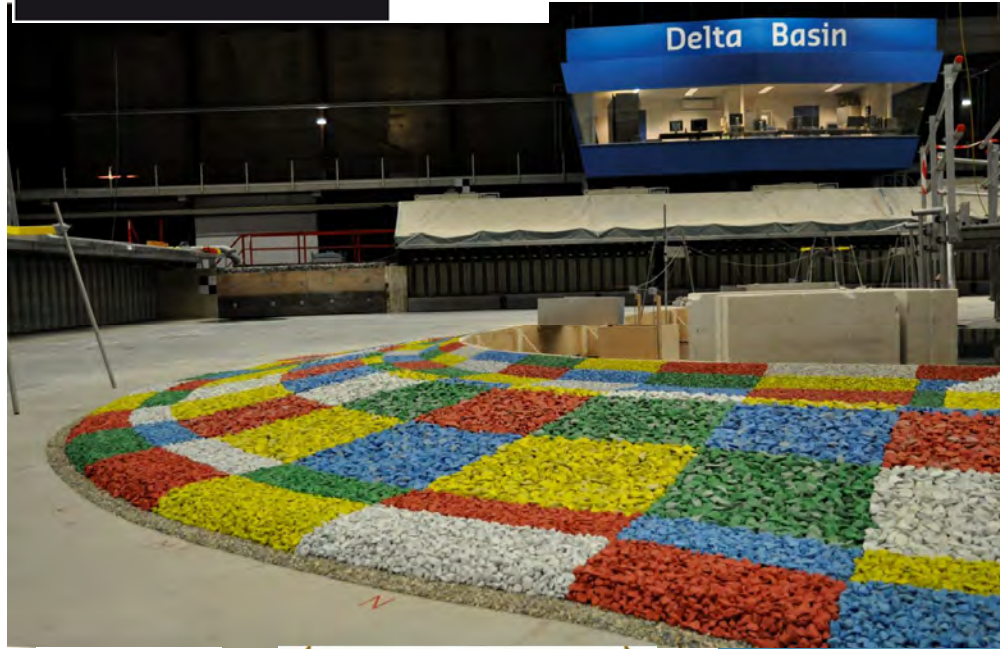

Van Oord   
Marine ingenuity

 **Boskalis**

TOUR



NCICD



PUSAIR



International knowledge partner

Deltares



# K-Water / KICT alliance - Korean rivers

(incl. KWRC and NIER)

International knowledge partner



- Reconstruction of Nakdong Han, Geum & Yeongsan rivers
- Safe, clean rivers, adequate water and nature conservation
- Collaboration with Korea Water Resources Corporation and National Institute of Environmental Research

Deltares



# NWS Alliance - Flood forecasting USA



**International knowledge partner**

**Support for National Weather Service and Forecasting Centres during implementation of their own system based on Delft-FEWS**





# USGS alliance – San Francisco bay model

**AGU FALL MEETING**  
San Francisco | 14 – 18 December 2015



International knowledge partner





# HKND alliance - Nicaragua landbridge (Panama revisited)



This chain of reserves, part of the Mesoamerican Biological Corridor, protects migratory routes between North and South America.

Lands of the Rama, Garifuna, Ulwa and Miskitu peoples lie along the Caribbean coast. Mayangna lands mostly border Honduras.



**President Ortega / CEO Wang Jing**

**International knowledge partner**



**Deltares**



# Rio Tinto alliance - Simandou terminal project

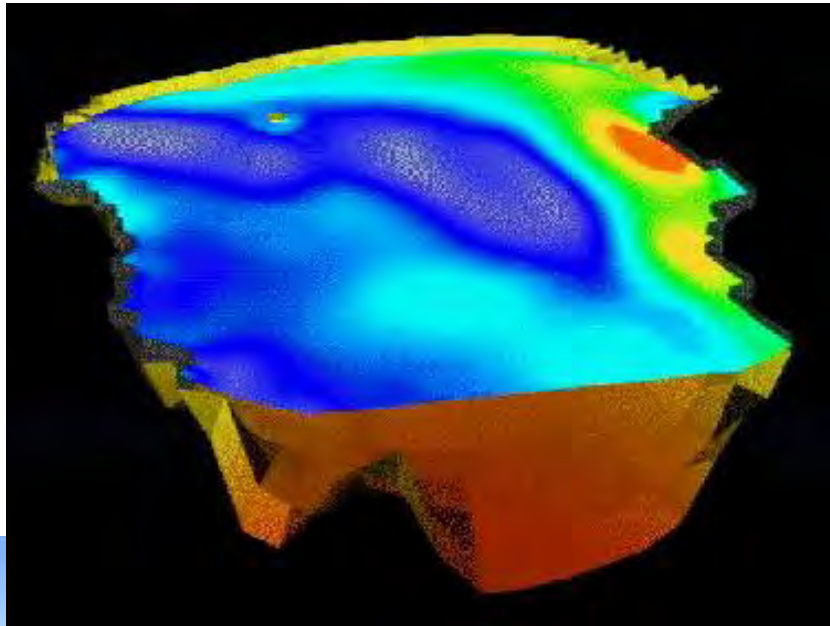

**Rio Tinto seals \$20bn iron ore development project with Guinea**

**Deltares**

10 december 2015



# Tidal Lagoon Power alliance - Swansea Bay UK

- A six-mile long seawall loops two miles out to sea
- 16 underwater turbines generating electricity on both rising and falling tide
- Enough renewable power would be produced for 155,000 homes

International knowledge partner



320 MW  
14 hrs/day

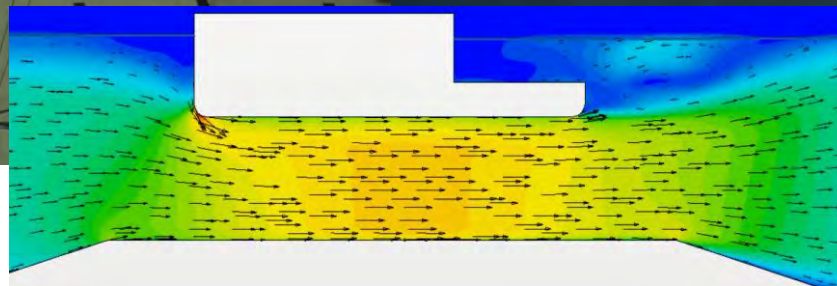
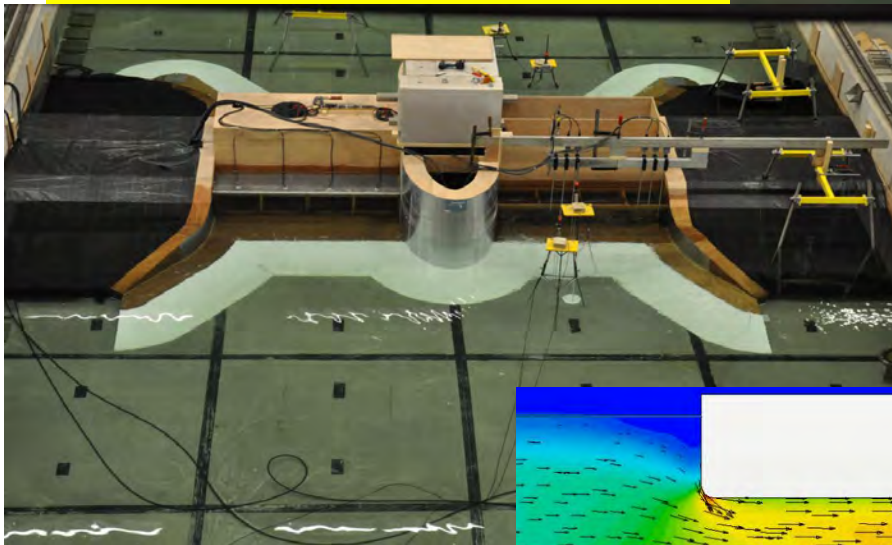

Z  
Y X

supV (m/s)  
0.10 0.94 1.8 2.6 3.5 4.3



Deltares



# Turbine scale model 1:35

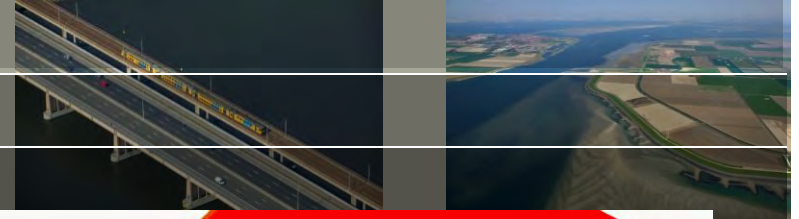

Rotational physical scale model

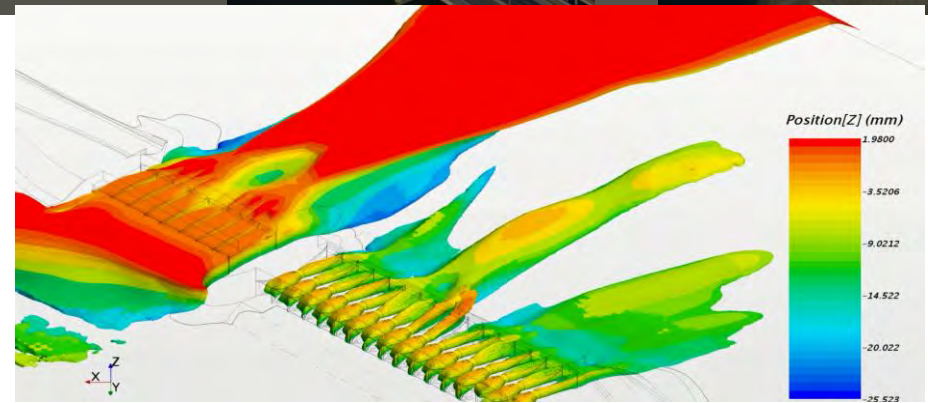

Outflow from turbines

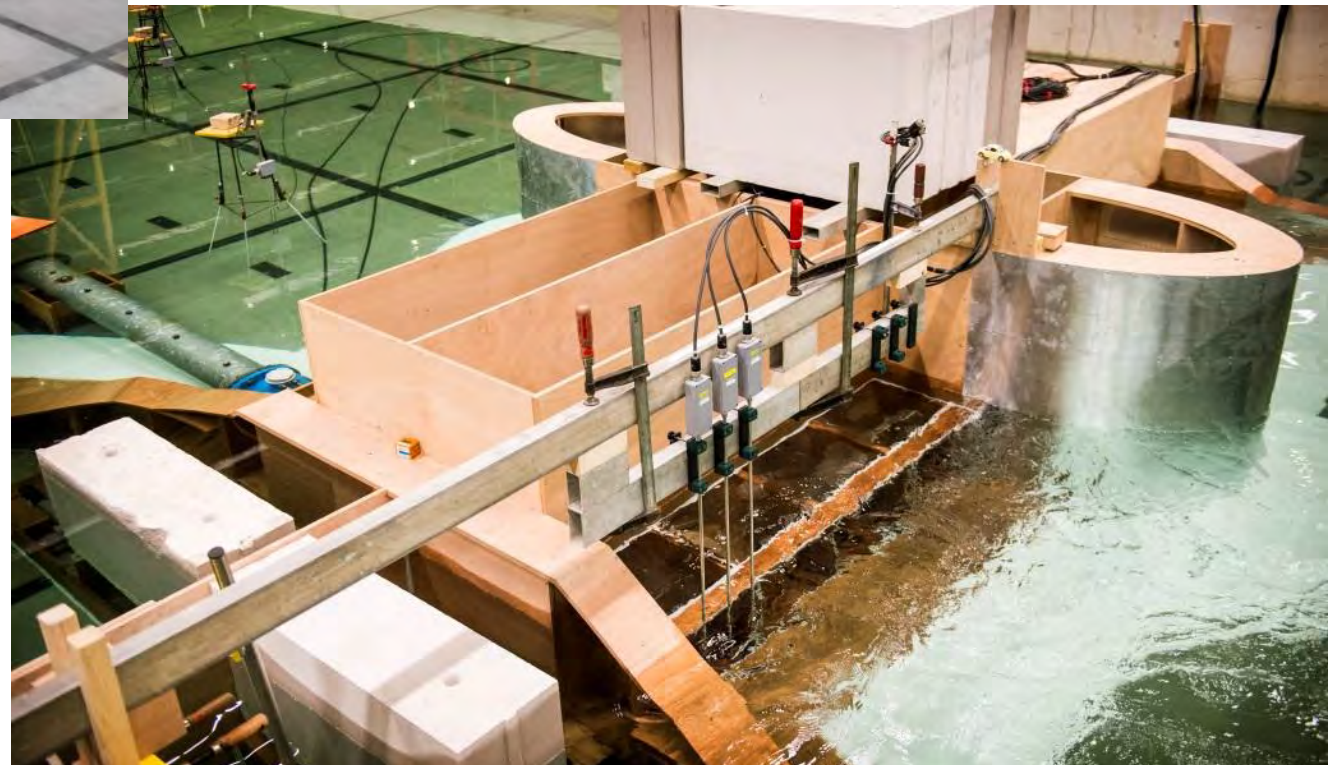



# CVN alliance - Flood Protection Venice



CONSORZIO VENEZIA NUOVA

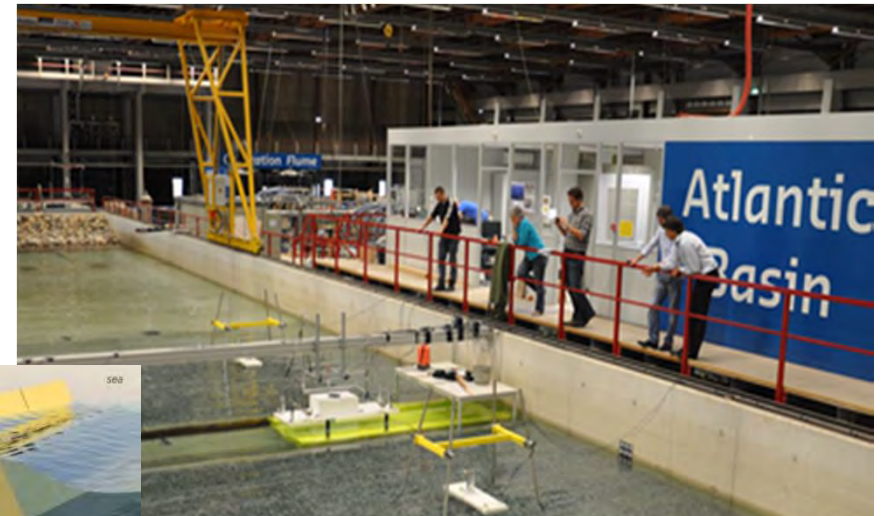
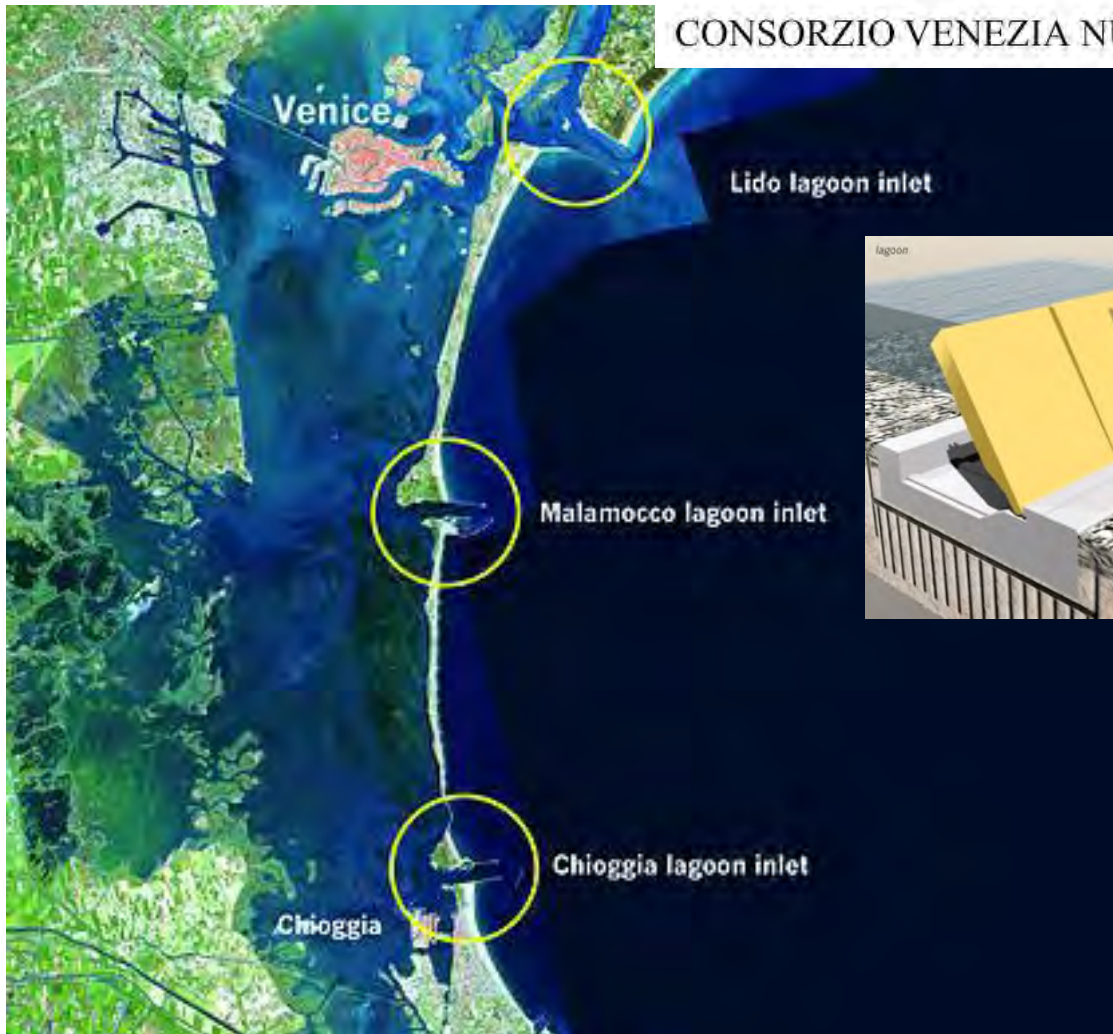

Strukton

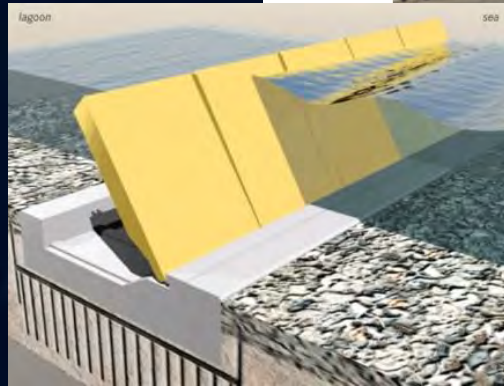

International knowledge partner

Deltares



# Tennet alliance - HVDC-stations offshore wind

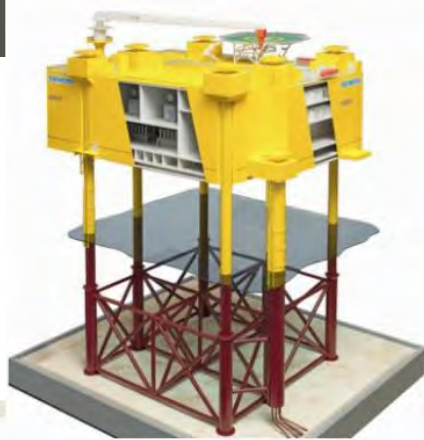

- Wind farm cluster BorWin**
- Projected wind farms\*
- Albatros I
  - BARD Offshore 1
  - Deutsche Bucht
  - Global Tech 1
  - Veja Mate

- Wind farm cluster DoiWin**
- Projected wind farms\*
- Borkum Riffgrund 1
  - Borkum Riffgrund 2
  - Gode Wind 1
  - Gode Wind 2
  - MEG Offshore I
  - Nordsee One
  - Trianel Windpark Borkum

- Wind farm cluster SylWin**
- Projected wind farms\*
- Butendiek
  - Dan Tysk
  - Sandbank

- Wind farm cluster HelWin**
- Projected wind farms\*
- Amrumbank West
  - Meerwind Süd/Ost
  - Nordsee Ost



Siemens HVDC platform  
 HVDC platform from others  
 \*With consented grid connection (Jan 2014)

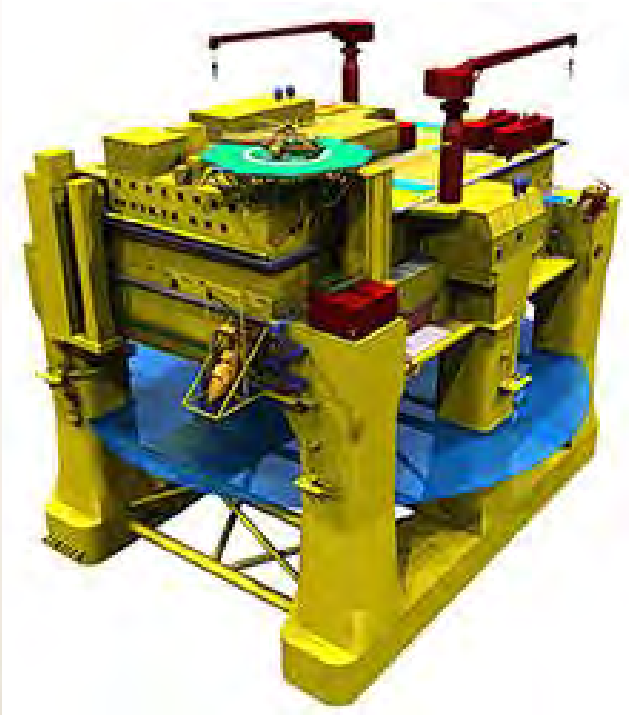

**Deltares**



# HVDC stations – scour research

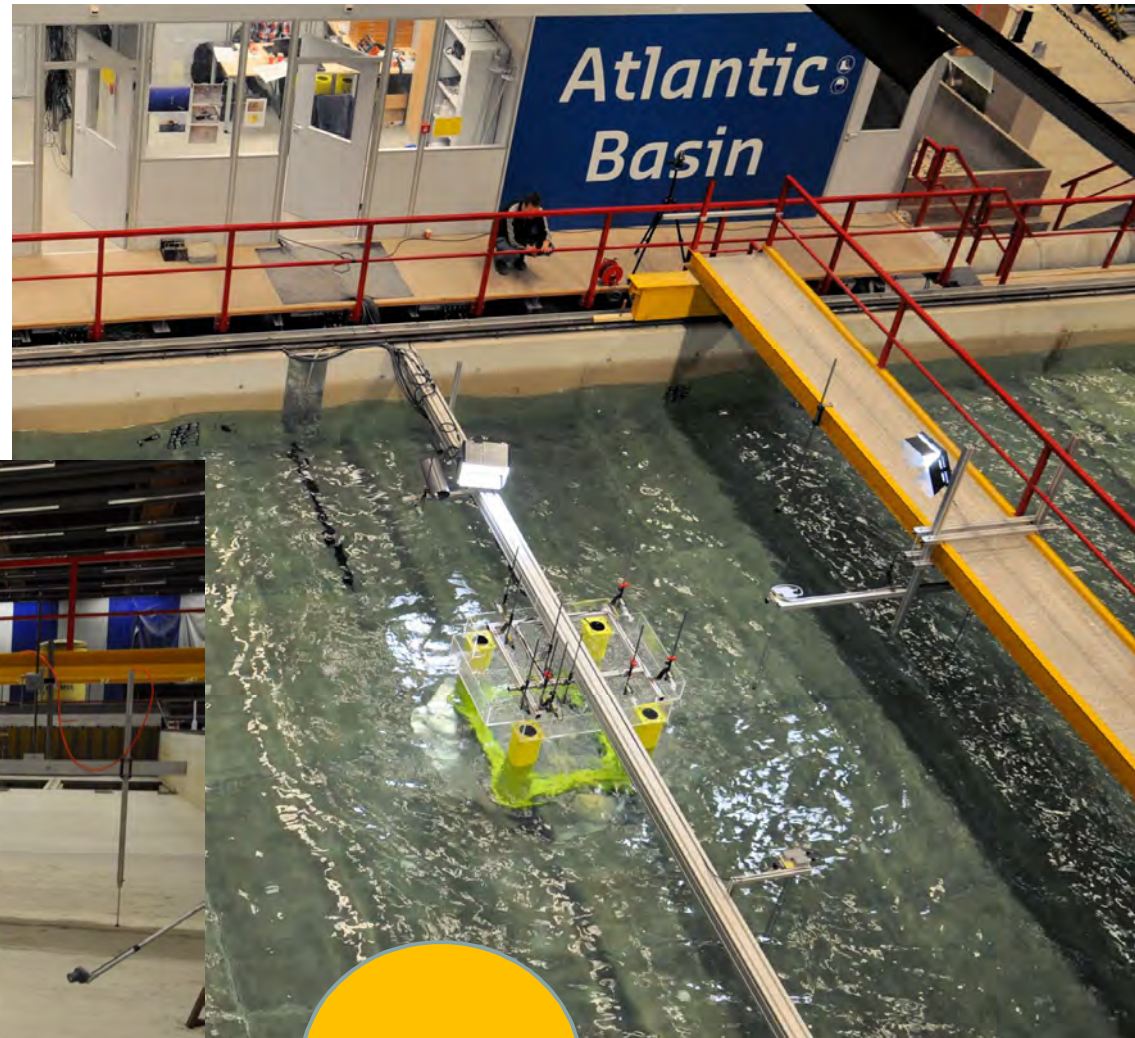
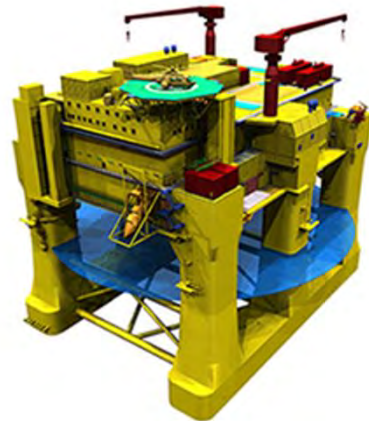
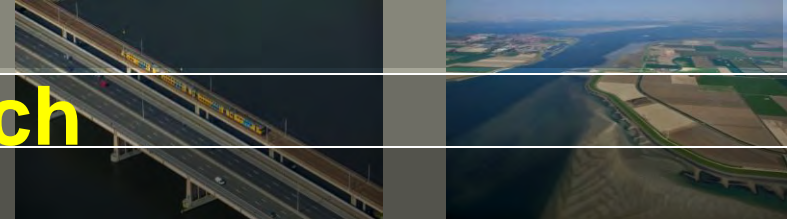

TOUR



# MoT alliance - 2<sup>nd</sup> Bosphorus Canal

## PM Erdoğan announces 'crazy project' as Kanal İstanbul





# Modes of cooperation

Deltares cooperates with contractors and client/operators  
In different roles, projectphases and/or contract stages

pre-contract  
design  
construction (building stages)  
workability assessment  
maintenance  
contract research (a.o.JIP's)  
EIA  
expert judgement  
software tools  
training, curriculum building

Deltares combines expertise and knowledge tools (experimental and numerical models, field measurements, etc.) in order to achieve a cost-effective, fit-for-purpose advice

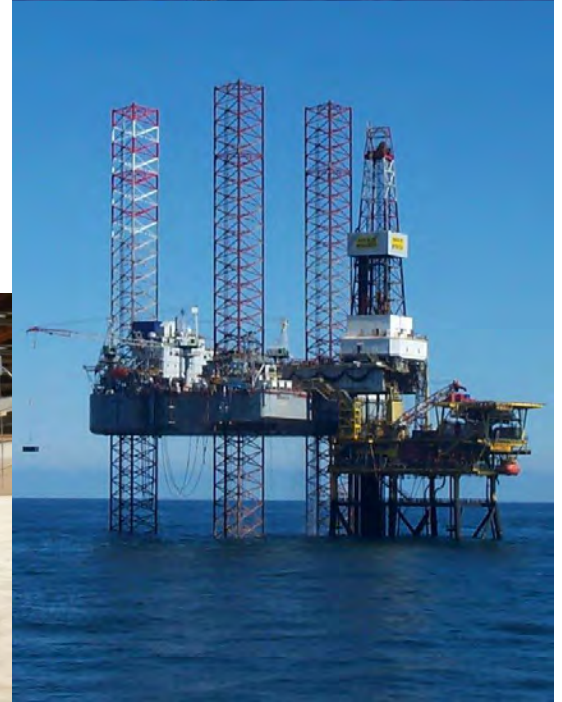



# Annual review 2014

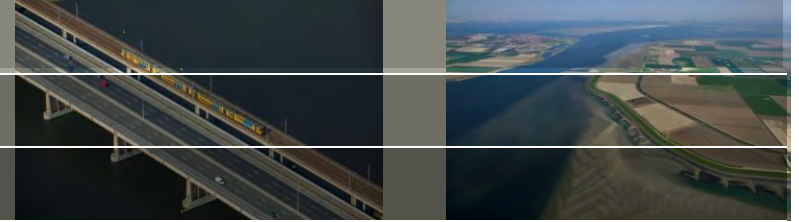

Only digital (<http://annualreport2014.deltares.nl/>)

